

# Sonde e sensori

## Probes and sensors

# CAREL



Guida alla scelta e all'installazione ottimale  
Selection and optimal installation guide

**LEGGI E CONSERVA  
QUESTE ISTRUZIONI**  
**READ AND SAVE  
THESE INSTRUCTIONS**

  **NO POWER  
& SIGNAL  
CABLES  
TOGETHER**  
**READ CAREFULLY IN THE TEXT!**

WARNING



CAREL bases the development of its products on decades of experience in HVAC, on the continuous investments in technological innovations to products, procedures and strict quality processes with in-circuit and functional testing on 100% of its products, and on the most innovative production technology available on the market. CAREL and its subsidiaries nonetheless cannot guarantee that all the aspects of the product and the software included with the product respond to the requirements of the final application, despite the product being developed according to start-of-the-art techniques.

The customer (manufacturer, developer or installer of the final equipment) accepts all liability and risk relating to the configuration of the product in order to reach the expected results in relation to the specific final installation and/or equipment. CAREL may, based on specific agreements, act as a consultant for the positive commissioning of the final unit/application, however in no case does it accept liability for the correct operation of the final equipment/system.

The CAREL product is a state-of-the-art product, whose operation is specified in the technical documentation supplied with the product or can be downloaded, even prior to purchase, from the website [www.CAREL.com](http://www.CAREL.com).

Each CAREL product, in relation to its advanced level of technology, requires setup / configuration / programming / commissioning to be able to operate in the best possible way for the specific application. The failure to complete such operations, which are required/indicated in the user manual, may cause the final product to malfunction; CAREL accepts no liability in such cases.

Only qualified personnel may install or carry out technical service on the product. The customer must only use the product in the manner described in the documentation relating to the product.

In addition to observing any further warnings described in this manual, the following warnings must be heeded for all CAREL products:

- Prevent the electronic circuits from getting wet. Rain, humidity and all types of liquids or condensate contain corrosive minerals that may damage the electronic circuits. In any case, the product should be used or stored in environments that comply with the temperature and humidity limits specified in the manual.
- Do not install the device in particularly hot environments. Too high temperatures may reduce the life of electronic devices, damage them and deform or melt the plastic parts. In any case, the product should be used or stored in environments that comply with the temperature and humidity limits specified in the manual.
- Do not attempt to open the device in any way other than described in the manual.
- Do not drop, hit or shake the device, as the internal circuits and mechanisms may be irreparably damaged.
- Do not use corrosive chemicals, solvents or aggressive detergents to clean the device.
- Do not use the product for applications other than those specified in the technical manual.

All of the above suggestions likewise apply to the controllers, serial boards, programming keys or any other accessory in the CAREL product portfolio. CAREL adopts a policy of continual development. Consequently, CAREL reserves the right to make changes and improvements to any product described in this document without prior warning.

The technical specifications shown in the manual may be changed without prior warning.

The liability of CAREL in relation to its products is specified in the CAREL general contract conditions, available on the website [www.CAREL.com](http://www.CAREL.com) and/or by specific agreements with customers; specifically, to the extent where allowed by applicable legislation, in no case will CAREL, its employees or subsidiaries be liable for any lost earnings or sales, losses of data and information, costs of replacement goods or services, damage to things or people, downtime or any direct, indirect, incidental, actual, punitive, exemplary, special or consequential damage of any kind whatsoever, whether contractual, extra-contractual or due to negligence, or any other liabilities deriving from the installation, use or impossibility to use the product, even if CAREL or its subsidiaries are warned of the possibility of such damage.

DISPOSAL



INFORMATION FOR USERS ON THE CORRECT HANDLING OF WASTE ELECTRICAL AND ELECTRONIC EQUIPMENT (WEEE)

In reference to European Union directive 2002/96/EC issued on 27 January 2003 and the related national legislation, please note that:

- WEEE cannot be disposed of as municipal waste and such waste must be collected and disposed of separately;
- the public or private waste collection systems defined by local legislation must be used. In addition, the equipment can be returned to the distributor at the end of its working life when buying new equipment;
- the equipment may contain hazardous substances: the improper use or incorrect disposal of such may have negative effects on human health and on the environment;
- the symbol (crossed-out wheeled bin) shown on the product or on the packaging and on the instruction sheet indicates that the equipment has been introduced onto the market after 13 August 2005 and that it must be disposed of separately;
- in the event of illegal disposal of electrical and electronic waste, the penalties are specified by local waste disposal legislation.

**Warranty on the materials:** 2 years (from the date of production, excluding consumables).

**Approval:** the quality and safety of CAREL INDUSTRIES Hqs products are guaranteed by the ISO 9001 certified design and production system.

**WARNING:** separate as much as possible the probe and digital input signal cables from the cables carrying inductive loads and power cables to avoid possible electromagnetic disturbance. Never run power cables (including the electrical panel wiring) and signal cables in the same conduits.



**READ CAREFULLY IN THE TEXT!**



# Contents

<b>1. PASSIVE TEMPERATURE SENSORS</b>	<b>7</b>
1.1 Selection guide based on the application .....	7
<b>2. OBSERVATIONS ON HEAT TRANSMISSION IN TEMPERATURE MEASUREMENTS</b>	<b>8</b>
<b>3. ACTIVE TEMPERATURE AND HUMIDITY SENSORS</b>	<b>8</b>
<b>4. ACTIVE AIR QUALITY SENSORS</b>	<b>9</b>
<b>5. REFRIGERANT GAS LEAKAGE SENSORS (R22, R134A, R290, R404A, R407C-F, R410A, R744, ETHYLENE)</b>	<b>9</b>
<b>6. PRESSURE SENSORS</b>	<b>10</b>
<b>7. DIFFERENTIAL PRESSURE SENSORS</b>	<b>10</b>
<b>8. FLOOD SENSORS</b>	<b>11</b>
<b>9. FROST SENSORS</b>	<b>11</b>
<b>10. SMOKE-FIRE SENSORS</b>	<b>11</b>
<b>11. LEVEL SENSORS</b>	<b>11</b>
<b>12. INSTALLATION DIAGRAMS BY APPLICATION</b>	<b>12</b>
12.1 AHU.....	12
12.2 HVAC: A/W - W/W chillers/heat pumps .....	14
12.3 CRAC.....	16
12.4 CRAC CW .....	18
12.5 HVAC: Technological/process cooling application Air/water chillers.....	20
12.6 HVAC: Commercial/residential applications - Rooftop.....	22
12.7 Blast chillers/freezers.....	24
12.8 Stand-alone showcases/bottle coolers.....	26
12.9 Water-cooled stand-alone showcases.....	28
12.10 Centralised/multiplexed cabinets.....	30
12.11 Cold rooms.....	32
12.12 Transcritical CO <sub>2</sub> systems.....	34
12.13 Subcritical CO <sub>2</sub> systems.....	35
<b>13. FURTHER SUGGESTIONS</b>	<b>36</b>
13.1 Room temperature and humidity sensors.....	36
13.2 Duct temperature and humidity sensors.....	37
13.3 Temperature sensors.....	38
13.4 Pressure sensors.....	38
13.5 Gas leakage sensors.....	38



# 1. PASSIVE TEMPERATURE SENSORS

**Preamble:** the purpose of this manual is to guide users in choosing and correctly installing probes, so as to reduce typical measurement errors resulting from:

- the influence of thermal contact resistance, the conductive material and the environment surrounding the probe;
- radiation;
- temperature stratification.

## 1.1 Selection guide based on the application

The choice of the best installation conditions for a probe or sensor depends on the measurement requirements (what needs to be measured, where are the sensors positioned? E.g. low temperature and high humidity – probable condensate and frost formation on the sensor;

high temperature – damage to the sheath or the fixing system):

1. Based on the fluid (gas or liquid), static or moving, which determines stratification of the fluid measured, heat exchange with the measurement system (sensor element, sheath, tubing, etc.); everything that increases thermal resistance and inertia and therefore causes various reading errors;
2. Based on the dynamics (if the phenomenon measured is very slow with small variations over time, or alternatively varies considerably in a short time);
4. Based on the operating range with positive – negative temperature variations, or alternatively positive or negative temperature variations only;
5. Based on the presence and type of contaminants (no UV -> no direct exposure to sunlight of the probe cable or plastic enclosures).

**Note:** the application diagrams shown below represent typical installations. Some applications may be a combination of several diagrams.

P/N	Type	Working range [°C]	IP	Casing-cap		Material		NOTES
				Ø [mm]	L [mm]	cap	cable	
NTC*HP*	NTC	-50T105	IP67	6x5	15	Polyolefin	Polyolefin	Single insulated cable
NTC*WH*	NTC	-50T105	IP68	6	50	AISI316	TPE	
NTC*WF*	NTC	-50T105	IP67	4	40	AISI316	TPE	
NTC*WP*	NTC	-50T105	IP67	6	100/200/300	AISI316	TPE	
NTC*HF*	NTC	-50T105	IP67	6X6	20	TPE	TPE	With cable tie, single insulated cable
NTC*WS*	NTC	-40T105	IP67	6x6	20	TPE + Cu	TPE	With cable tie, double insulated cable
NTC*HT*	NTC	-30T150	IP67	5	20/50	PE/AISI316	PE	Two versions (PE and AISI)
NTC*LT*	NTC	-80T105	IP67	6x6	150	AISI316		
NTC*PS*	NTC	-50T105	IP67	98x20	105	Santoprene	TPE	Product temperature simulation
TSN*	NTC	-40T120	IP68	3	13	AISI316	-	Direct immersion M 1/8 Gas - PN40
TSC*	NTC	-40T90	IP68	4	15	Nickel-plated brass	TPE	Direct immersion M14 - PN40
NTC*INF*	NTC	-50T90	IP67	5/4	150/169/100	AISI304/316	Silicone	Suitable for use with food to measure product core temperature
NTC*WG*	NTC	-50T105	IP67	6x6	40	Aluminium	TPE	Used on showcases together with humidity probe to activate anti-sweat
PT100*	PT100	-50T250 0T400	IP65	6	100	AISI316	Silicone rubber	
PT1*HP*	PT1000	-50T105	IP67	6x5	15	Polyolefin	Polyolefin	Single insulated cable
PT1*WF*	PT1000	-50T105	IP67	4	40	AISI316	TPE	
PT1*WP*	PT1000	-50T105	IP67	6	50	AISI316	TPE	
PT1*HT*	PT1000	-50T250	IP67	6	40	AISI304	Silicon resin	
PT1*HF*	PT1000	-50T105	IP67	6x6	20	TPE	TPE	With cable tie, single insulated cable
PT1*PS*	PT1000	-50T105	IP67	98x20	105	Santoprene	TPE	Special applications
TST*	PT1000	-40T120	IP68	3	13	AISI316	-	Direct immersion M 1/8 Gas - PN40
TSM*	PT1000	-40T90	IP68	4	15	Nickel-plated brass	TPE	Direct immersion M14 - PN25
TSQ*	PT1000	-50T350	IP65	3	150	AISI316		
PT1*INF*	PT1000	-50T200	IP67	5/4	100	AISI316	TPE	Suitable for use with food to measure product core temperature
PTC*	PTC	-30T105	IP67	6	40		PVC	

Tab. 1.a

**Note:** for further technical details, see the passive sensor manual +030220655 (IT-EN).



## 2. OBSERVATIONS ON HEAT TRANSMISSION IN TEMPERATURE MEASUREMENTS

**Preamble:** whatever method is used to measure temperature, the measured temperature is never the actual temperature of the fluid being measured.

The deviation from the real value (which represents the measurement error) is a result of heat transmission, a process that affects any object or fluid with a difference in temperature from another nearby fluid or object, or alternatively a dynamic variation in temperature (difference from previous values).

The following factors cause the measurement to deviate from the real value:

1. Temperature difference in the area surrounding the point of measurement;
2. Thermal mass of the temperature measuring system (e.g. pipe, socket, probe), which increases the total measurement time constant.

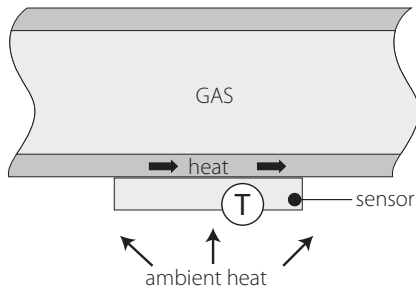

Commonly, when measuring the temperature of a fluid, the influence of the temperature difference in the area surrounding the point of measurement is often underestimated. When the difference between the point of measurement and the surrounding environment is significant (in the tens of degrees), the error is no longer negligible.

When needing to control a temperature that is subject to variations, precision of control will also depend on the measurement time constant:

the lower the time constant, the quicker control will respond to a changing temperature, and consequently the lower the instant error will be between the value read and the real value.

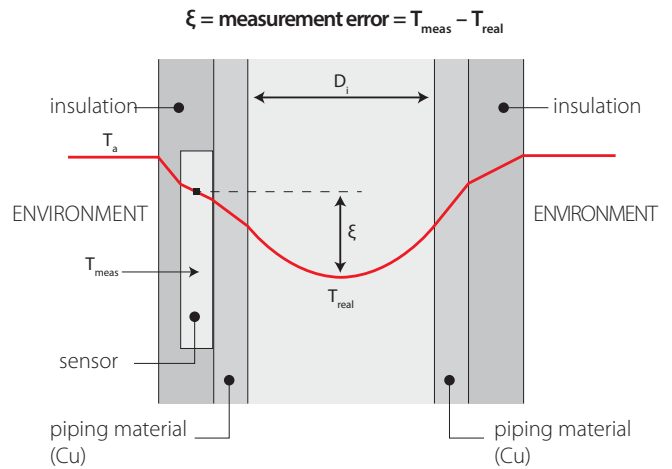

**Note:** the measurement error generated by the influence of ambient temperature is particularly important with smaller diameter piping: the ratio between masses (pipe and fluid) is in fact inversely proportional to pipe diameter.

$$\frac{A_e}{V_i} = \frac{D_e \cdot \pi}{D_i^2 \cdot \pi/4} \cong \frac{4}{D}$$

$A_e$  = outside surface area  
 $V_i$  = inside volume

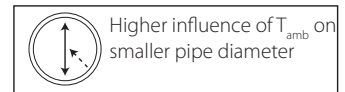

## 3. ACTIVE TEMPERATURE AND HUMIDITY SENSORS

	Type of output							
	Temperature	Humidity	Carel NTC	Carel NTC & -0.5-1 V / 4-20 mA	-0.5-1 V 4-20 mA	Carel NTC & 0-10 V	0-10 V	RS485 serial
Duct	-10 T60°C	-	DPDT011000	-	DPDT010000	-	-	DPDT014000
	-10 T60°C	10-90%	-	DPDC111000	DPDC110000	-	DPDC112000	DPDC114000
	-20-70°C	0-100%	-	-	DPDC210000	-	DPDC212000	DPDC214000
Industrial environment	-10 T60°C	-	DPPT011000	-	DPPT010000	-	-	DPPT014000
	-10 T60°C	10-90%	-	DPDC111000	DPDC110000	-	DPDC112000	DPDC114000
	-20-70°C	0-100%	-	-	DPDC210000	-	DPDC212000	DPDC214000
Wall-mounting	-10 T60°C	-	DPWT011000	-	DPWT010000	-	-	DPWT014000
	-10 T60°C	10-90%	-	DPWC111000	DPWC110000	DPWC115000	DPWC112000	DPWC114000
Remote sensor	-	30-90°C	-	-	ASIT030000	-	-	-
	-	30-90°C Cable L= 2m	-	-	ASET030000	-	-	-
	-	30-90°C Cable L= 3m	-	-	ASET030001	-	-	-
		30-90°C Cable L= 4m	-	-	ASET030002	-	-	-

Tab. 3.a

**Note:** for further technical details, see the active sensor manual +030220660 (IT-EN)



## 4. ACTIVE AIR QUALITY SENSORS

Carel DP*Q* P/Ns		
Version	Outputs	Carel part number
VOC air quality sensor, wall-mounting	0 to 10V – 4 to 20 mA	DPWQ306000
CO2 air quality sensor, wall-mounting	0 to 10V	DPWQ402000
VOC + CO2 air quality sensor, wall-mounting	0 to 10V	DPWQ502000
VOC air quality sensor, duct version	0 to 10V – 4 to 20 mA	DPDQ306000
CO2 air quality sensor, duct version	0 to 10V	DPDQ402000
VOC + CO2 air quality sensor, duct version	0 to 10V	DPDQ502000

Tab. 4.a

**Note:** for further technical details see the air quality sensor technical leaflets:

VOC	VOC + CO <sub>2</sub>
+050001290 - IT	+050001300 - IT
+050001291 - GB	+050001301 - GB
+050001292 - FR	+050001302 - FR
+050001293 - DE	+050001303 - DE
+050001294 - RU	+050001304 - RU



## 5. REFRIGERANT GAS LEAKAGE SENSORS (R22, R134A, R290, R404A, R407C-F, R410A, R744, ETHYLENE)

Semiconductor (IP41)	Semiconductor with 5 m remote sensor (IP66)	Description
DPWLA07000	DPWLA27000	R22 gas leak detector
DPWLB07000	DPWLB27000	R134a gas leak detector
DPWLC07000	DPWLC27000	R404a gas leak detector
DPWLR07000		R407a gas leak detector
DPWLD07000	DPWLD27000	R407c gas leak detector
DPWLS07000		R407f gas leak detector
DPWLE07000	DPWLE27000	R410a gas leak detector
DPWLT07000	DPWLT27000	R507a gas leak detector
DPWLG07000		NH3 gas leak detector
DPWLQ07000		ETHYLENE gas leak detector
DPWLP07000		R290 gas leak detector

Infrared (IP66)	Infrared with 5 m remote sensor (IP66)	Description
DPWL417000	DPWL427000	Sensor rilevam. gas CO <sub>2</sub>

Tab. 5.a

**Note:** for further technical details, see the specific manual: +0300035EN or +0300035IT





## 6. PRESSURE SENSORS

Choice of pressure sensor according to operating pressure.

Gas	Low temperature evaporator	Medium and high temperature evaporator	Condenser
R134a	SPKT0053R*/P* (0-5 V; -1.0-4.2 barg) SPKT0021C*/D* (4-20 mA; -0.5-7.0 barg) SPKS0019R1 (0-5 V; 0-9 barg) weld version	SPKT0013R*/P* (0-5 V; -1-9.3 barg) SPKT0011C*/D* (4-20 mA; 0-10 barg) SPKS0019R1 (0-5 V; 0-9 barg) weld version	SPKT0033R*/P* (0-5 V; 0-34.5 barg) SPKT0031C*/D* (4-20 mA; 0-30 barg) SPKS0039R1 (0-5 V; 0-34 barg) weld version
R290	SPKT0013R*/P* (0-5 V; -1-9.3 barg) SPKT0011C*/D* (4-20 mA; 0-10 barg) SPKS0019R1 (0-5 V; 0-9 barg) weld version	SPKT0013R*/P* (0-5 V; -1-9.3 barg) SPKT0011C*/D* (4-20 mA; 0-10 barg) SPKS0019R1 (0-5 V; 0-9 barg) weld version	SPKT0033R*/P* (0-5 V; 0-34.5 barg) SPKT0031C*/D* (4-20 mA; 0-30 barg) SPKS0039R1 (0-5 V; 0-34 barg) weld version
R404a	SPKT0013R*/P* (0-5 V; -1-9.3 barg) SPKT0011C*/D* (4-20 mA; 0-10 barg) SPKS0019R1 (0-5 V; 0-9 barg) weld version	SPKT0013R*/P* (0-5 V; -1-9.3 barg) SPKT0011C*/D* (4-20 mA; 0-10 barg) SPKS0019R1 (0-5 V; 0-9 barg) weld version	SPKT0033R*/P* (0-5 V; 0-34.5 barg) SPKT0031C*/D* (4-20 mA; 0-30 barg) SPKS0039R1 (0-5 V; 0-34 barg) weld version
R407A	SPKT0013R*/P* (0-5 V; -1-9.3 barg) SPKT0011C*/D* (4-20 mA; 0-10 barg) SPKS0019R1 (0-5 V; 0-9 barg) weld version	SPKT0013R*/P* (0-5 V; -1-9.3 barg) <sup>(1)</sup> SPKT0011C*/D* (4-20 mA; 0-10 barg) <sup>(1)</sup> SPKS0019R1 (0-5 V; 0-9 barg) weld version	SPKT0033R*/P* (0-5 V; 0-34.5 barg) SPKT0031C*/D* (4-20 mA; 0-30 barg) SPKS0039R1 (0-5 V; 0-34 barg) weld version
R407C	SPKT0013R*/P* (0-5 V; -1-9.3 barg) SPKT0011C*/D* (4-20 mA; 0-10 barg) SPKS0019R1 (0-5 V; 0-9 barg) weld version	SPKT0013R*/P* (0-5 V; -1-9.3 barg) <sup>(1)</sup> SPKT0011C*/D* (4-20 mA; 0-10 barg) <sup>(1)</sup> SPKS0019R1 (0-5 V; 0-9 barg) weld version	SPKT0033R*/P* (0-5 V; 0-34.5 barg) SPKT0031C*/D* (4-20 mA; 0-30 barg) SPKS0039R1 (0-5 V; 0-34 barg) weld version
R407F	SPKT0013R*/P* (0-5 V; -1-9.3 barg) SPKT0011C*/D* (4-20 mA; 0-10 barg) SPKS0019R1 (0-5 V; 0-9 barg) weld version	SPKT0013R*/P* (0-5 V; -1-9.3 barg) <sup>(1)</sup> SPKT0011C*/D* (4-20 mA; 0-10 barg) <sup>(1)</sup> SPKS0019R1 (0-5 V; 0-9 barg) weld version	SPKT0033R*/P* (0-5 V; 0-34.5 barg) SPKT0031C*/D* (4-20 mA; 0-30 barg) SPKS0039R1 (0-5 V; 0-34 barg) weld version
R410A	SPKT0043R*/P* (0-5 V; 0-17.3 barg) SPKT0041C*/D* (4-20 mA; 0-18.2 barg) SPKS00F9R1 (0-5 V; 0-19 barg) weld version	SPKT0043R*/P* (0-5 V; 0-17.3 barg) SPKT0041C*/D* (4-20 mA; 0-18.2 barg) SPKS00F9R1 (0-5 V; 0-19 barg) weld version	SPKT00B6R*/P* (0-5 V; 0-45 barg) SPKT00B1C*/D* (4-20 mA; 0-44.8 barg) SPKS00B9R1 (0-5 V; 0-45 barg) weld version
R717	SPKT0021C*/D* (4-20 mA; -0.5-.7 barg)	SPKT0011C*/D* (4-20 mA; 0-10 barg)	SPKT0031C*/D* (4-20 mA; 0-30 barg)
R744	SPKT00G1C*/D* (4-20 mA; 0-60 barg)	SPKT00G1C*/D* (4-20 mA; 0-60 barg)	SPKT00H8C* (4-20 mA; 0-120 barg) SPKT00D8C* (4-20 mA; 0-150 barg)

Tab. 6.a

(1): for HVAC applications, use respectively

- SPKT0043R\*/P\* (0-5 V 0-17.3 barg)
- SPKT0041C\*/D\* (4-20 mA 0-18.2 barg)
- SPKS00F9R1 (0-5 V 0-19 barg) weld version

**Specific documents:** for further technical details see the pressure transducer technical leaflets:

- cable and connector +050000484
- 4-20 mA C series +050000486 (IT-EN) alternative: 4-20 mA D series +050000595 (IT-EN)
- 4-20 mA C series high pressure +050000596 (IT-EN)
- 0-5 V R series +050000485 (IT-EN) alternative: 0-5 V P series +050000598 (IT-EN)
- 0-5 V S series +050000488 (IT-EN)
- 0-5 V SPKS\* series weld version +050000489 (IT-EN)

**Note:** the SPKS\*R\* series weld-version sensors comply with F-GAS regulation 842/2006, which requires devices installed in the system to be hermetically sealed and solidly secured by welding.



## 7. DIFFERENTIAL PRESSURE SENSORS

See the specific technical leaflets:

4-20 mA active sensors +050000651 (IT-EN)

P/N	Working range (adjustable)	Output
SPKD00U5N0	0 - 1000 Pa	4 - 20 mA
	0 - 2500 Pa	
	0 - 3000 Pa	
	0 - 5000 Pa	
SPKD00C5N0	- 50 - + 50 Pa	4 - 20 mA
	- 100 - + 100 Pa	
	0 - + 50 Pa	
	0 - + 100 Pa	

Tab. 7.a



On-off sensors +050000645 (IT-EN)

P/N	Description	Range (mbar)	
DCPD000100	Differential pressure switch	0.5 - 5.0	
DCPD010100	Differential pressure switch	0.5 - 5.0	with connection kit
DCPD001100	Differential pressure switch	0.2 - 2.0	
DCPD011100	Differential pressure switch	0.2 - 2.0	with connection kit

Tab. 7.b



## 8. FLOOD SENSORS

Technical leaflet +050004116

P/N	Description
FLOE000010	Flood detector
FLOS000000	Spot probe
FLOR000000	Strip sensor 25 m

Tab. 8.a



## 9. FROST SENSORS

Technical leaflet +050000646

P/N	Description	Range (°C)
DCTF000320	Single-stage frost thermostat	-10 to 15

Tab. 9.a



## 10. SMOKE-FIRE SENSORS

Technical leaflet +050000520

Smoke

P/N	Power supply voltage
SFFS000000	12-24 Vdc

Tab. 10.a

Fire

P/N	Power supply voltage
SFFF000000	12-24 Vdc

Tab. 10.b



## 11. LEVEL SENSORS

Technical leaflet +0500075ML

P/N	Description
LSR0013000	Level sensor – 2" Gas mechanical connector
LSR0023000	Level sensor – flanged mechanical connector

Tab. 11.a



## 12. INSTALLATION DIAGRAMS BY APPLICATION

### 12.1 AHU

KEY

$\text{T}$	Temperature
rH%	Relative humidity
$\Delta\text{P}$	Differential pressure
$\text{CO}_2$	$\text{CO}_2$
$\text{Voc}$	Volatile organic compounds

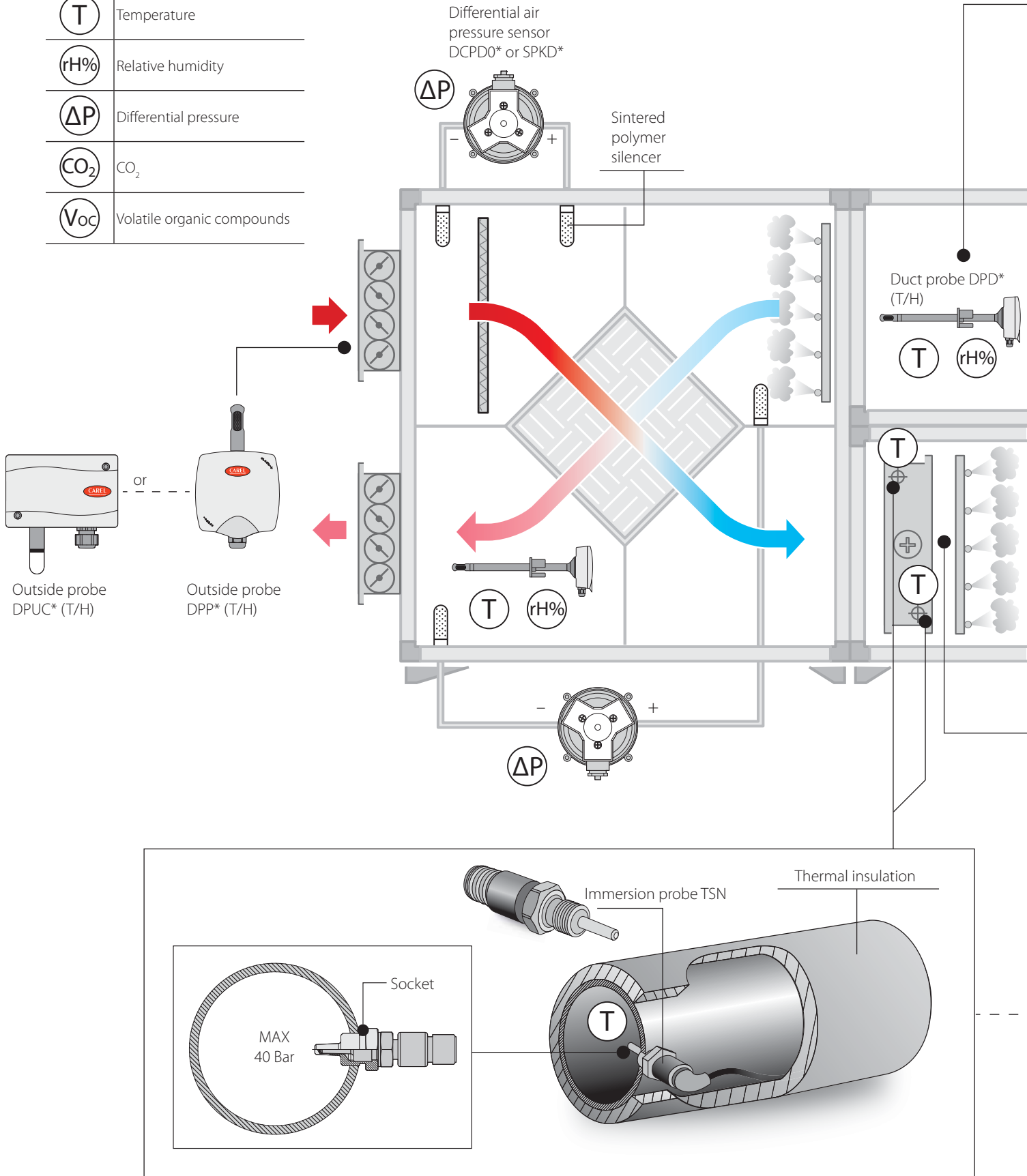

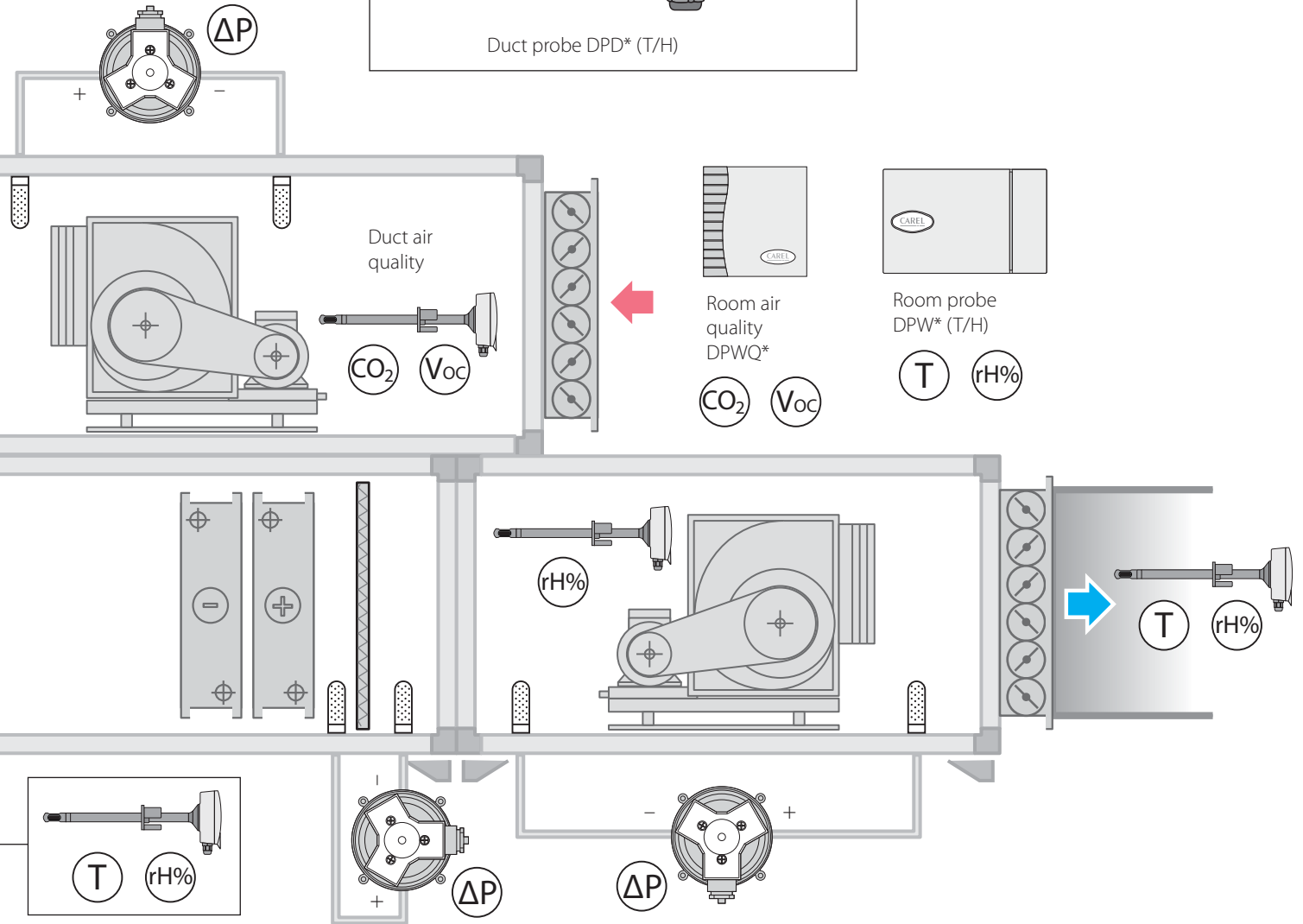
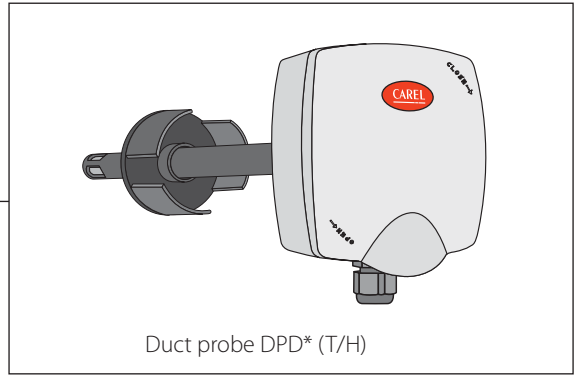

Alternative solutions

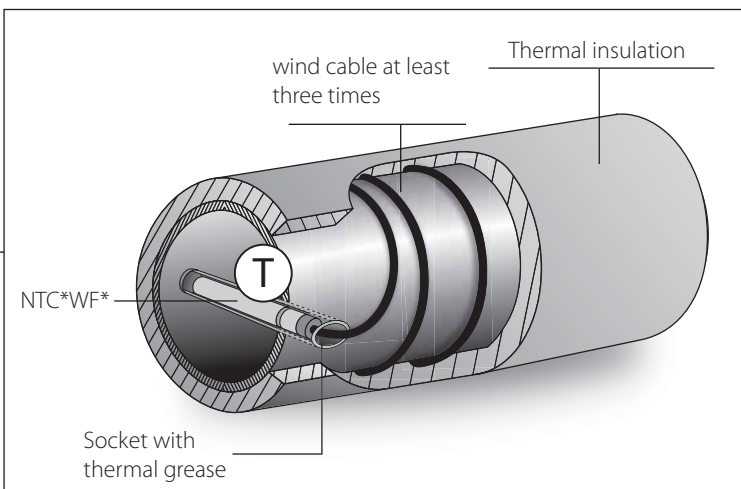

12.2 HVAC: /W - W/W chillers/heat pumps

KEY

T	Temperature
P	Pressure

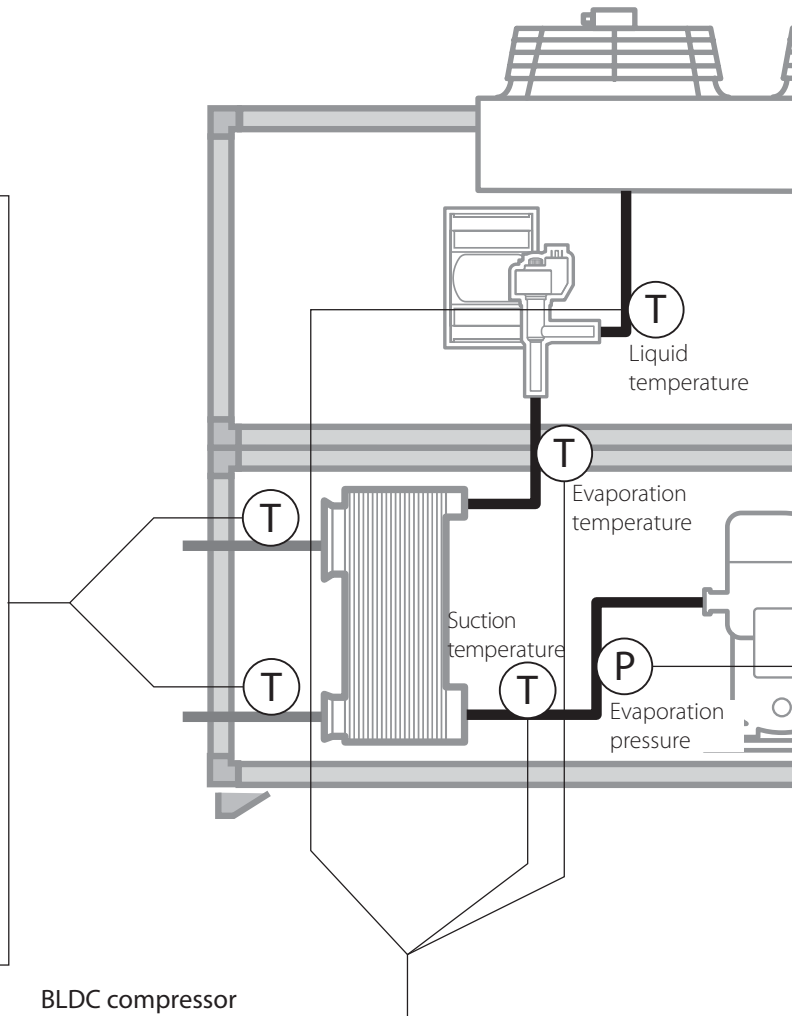
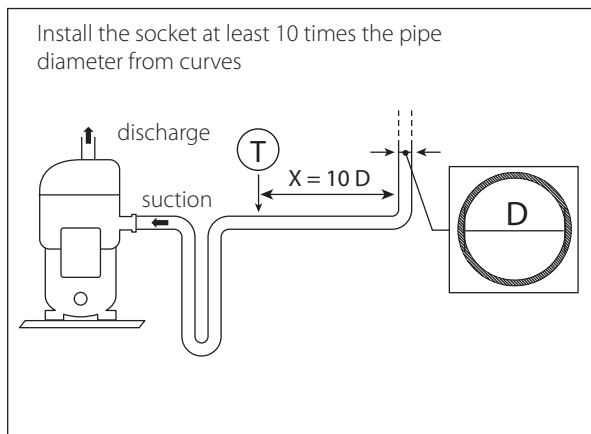
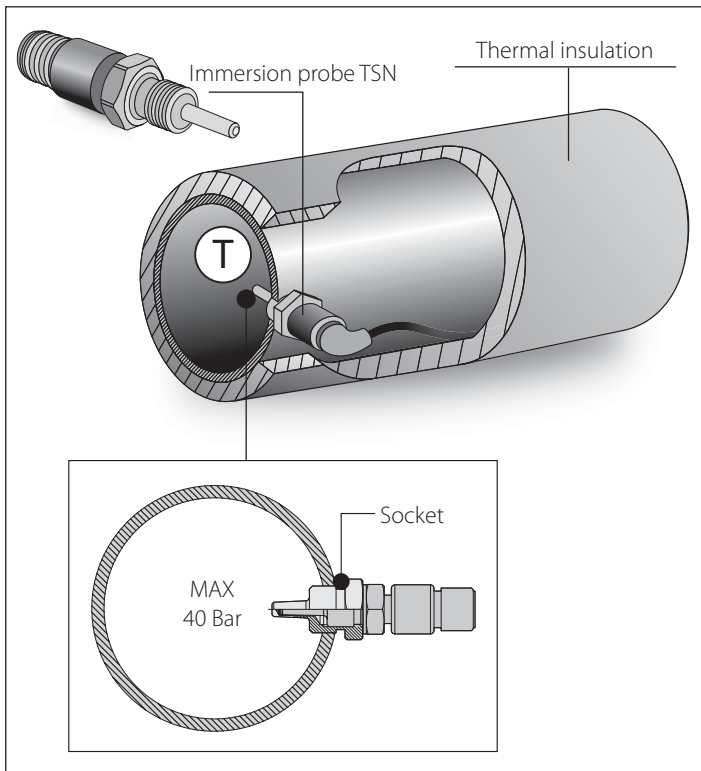

BLDC compressor

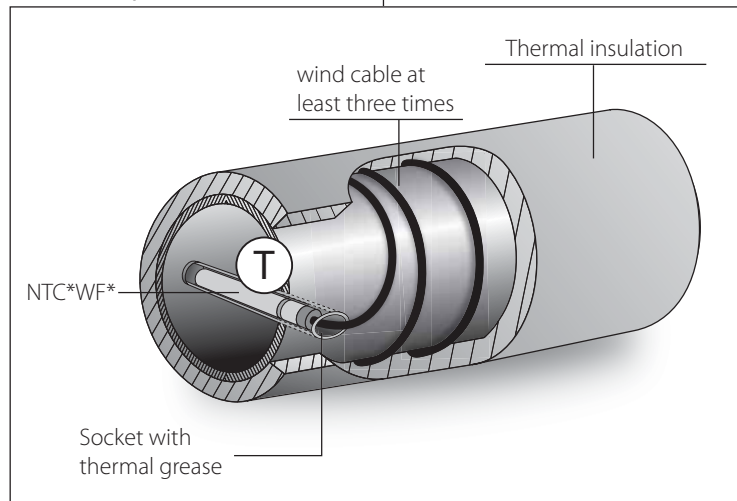

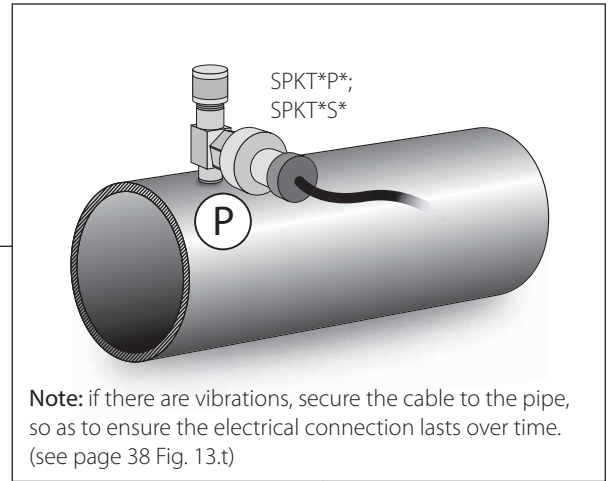
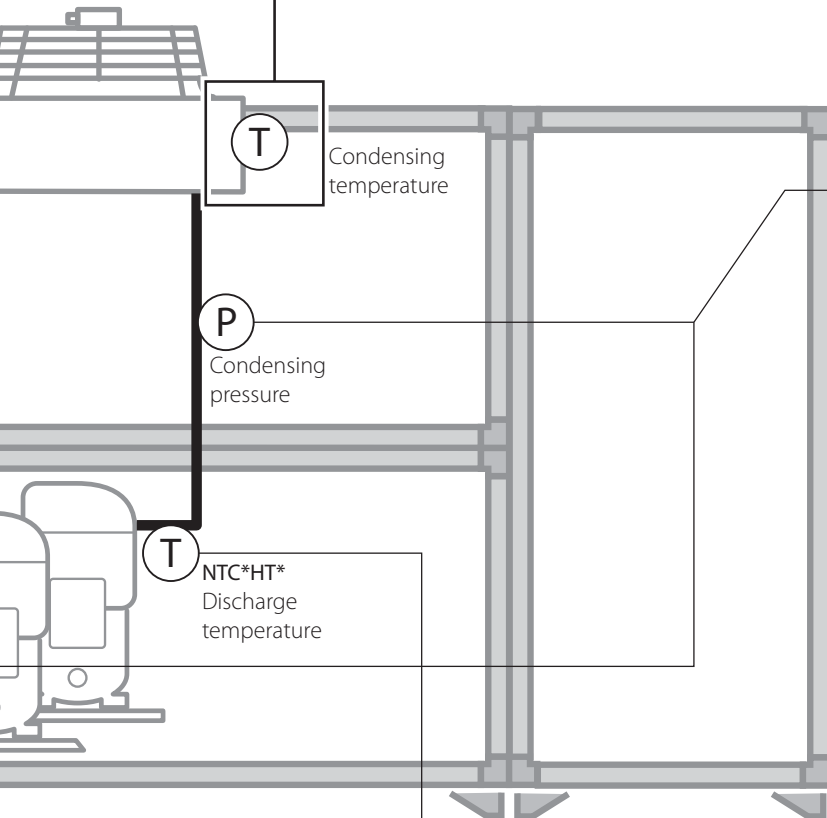
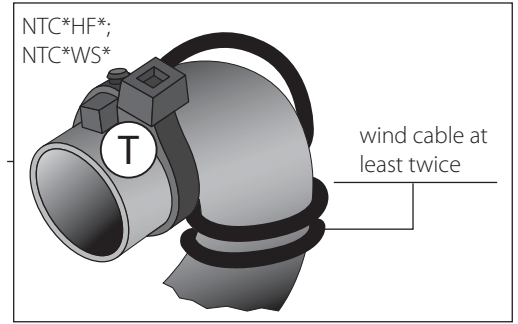
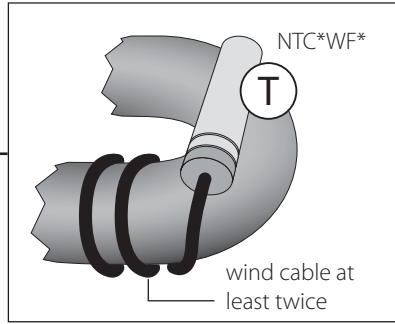
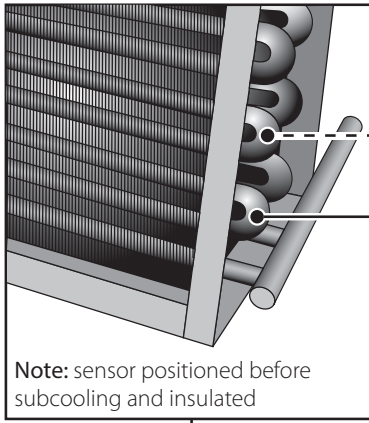

Connection with capillary

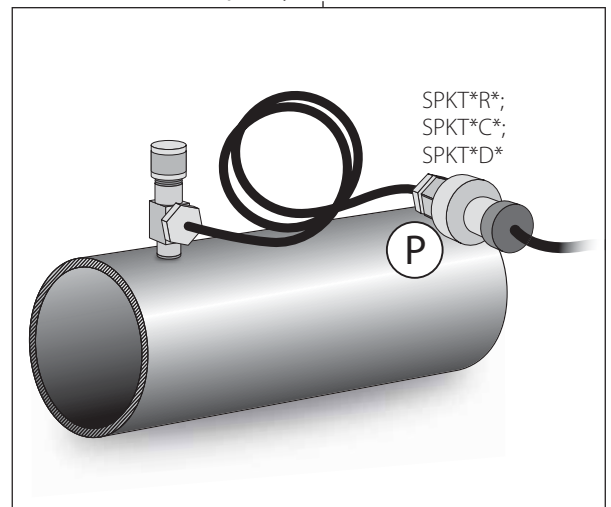

ON/OFF compressor

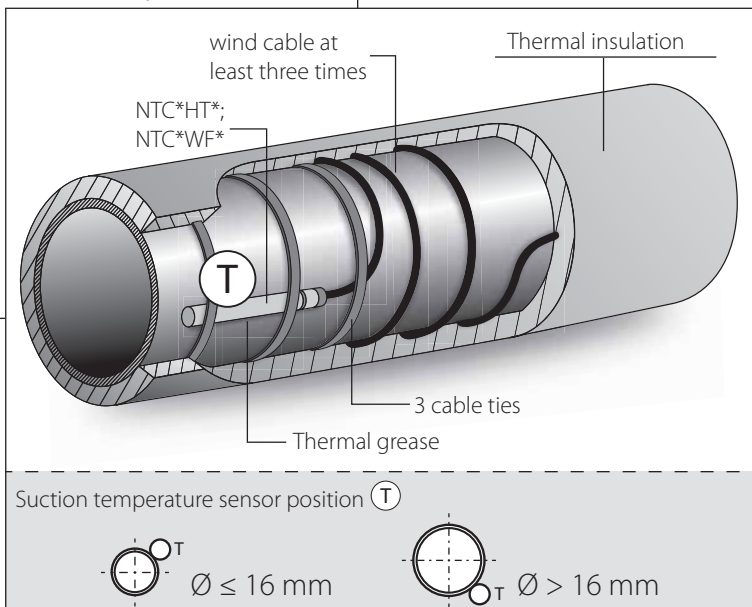

Welded connection

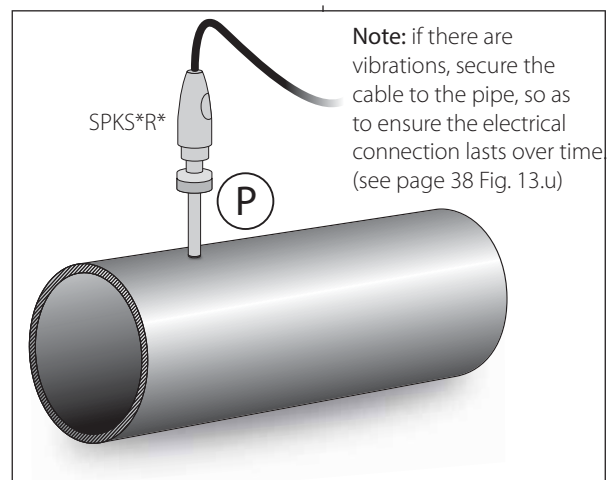

12.3 CRAC

KEY

<b>T</b>	Temperature
<b>P</b>	Pressure
<b>rH%</b>	Relative humidity
<b>ΔP</b>	Differential pressure
<b>S</b>	Smoke
<b>F</b>	Fire
<b>L</b>	Flood sensor

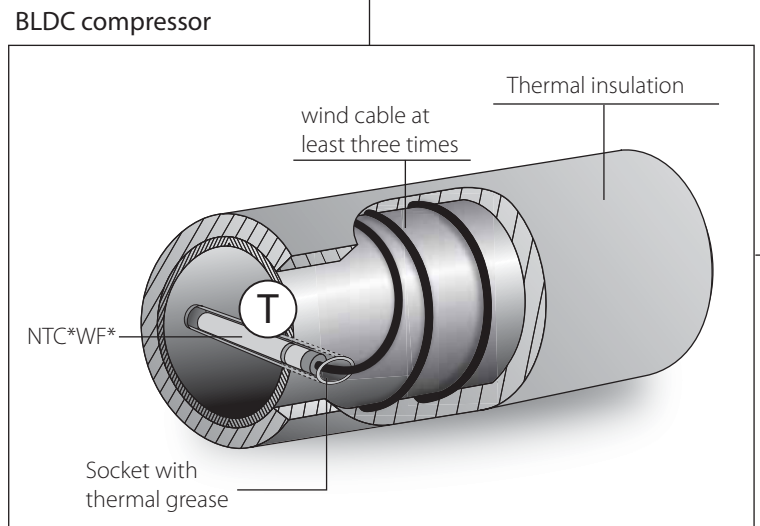
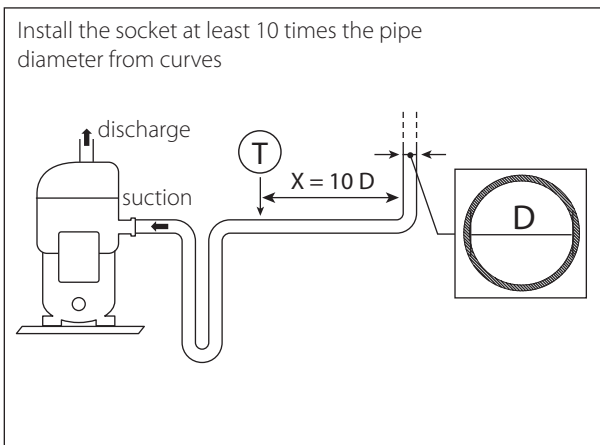
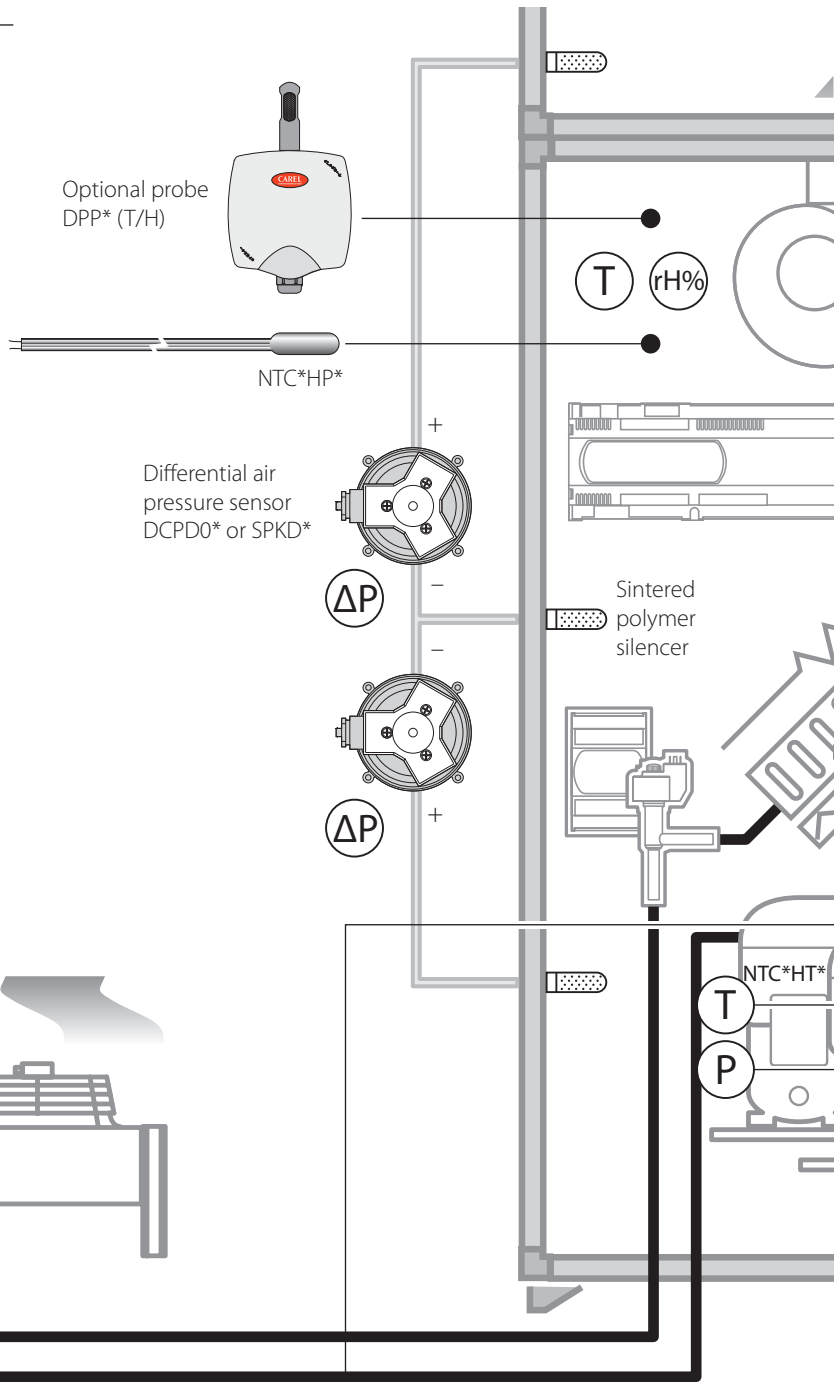
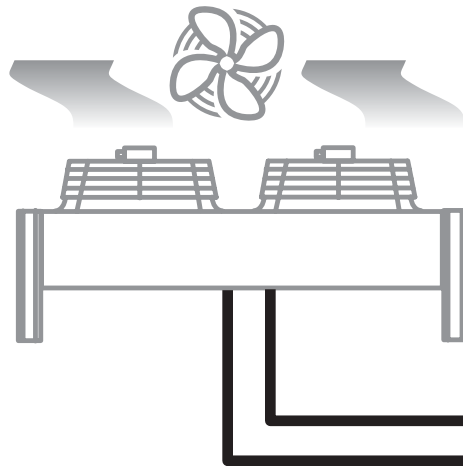



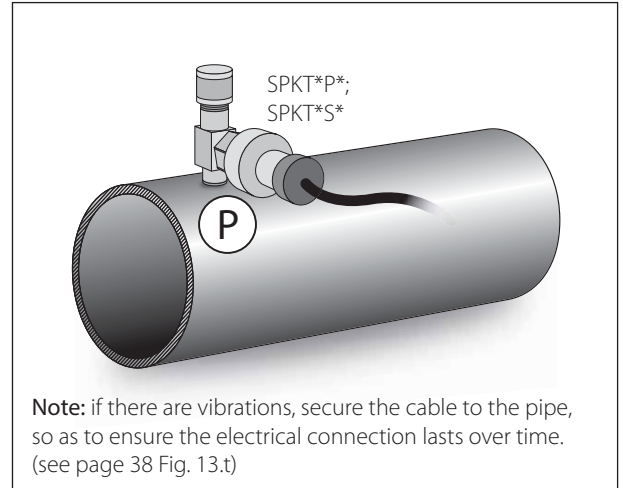
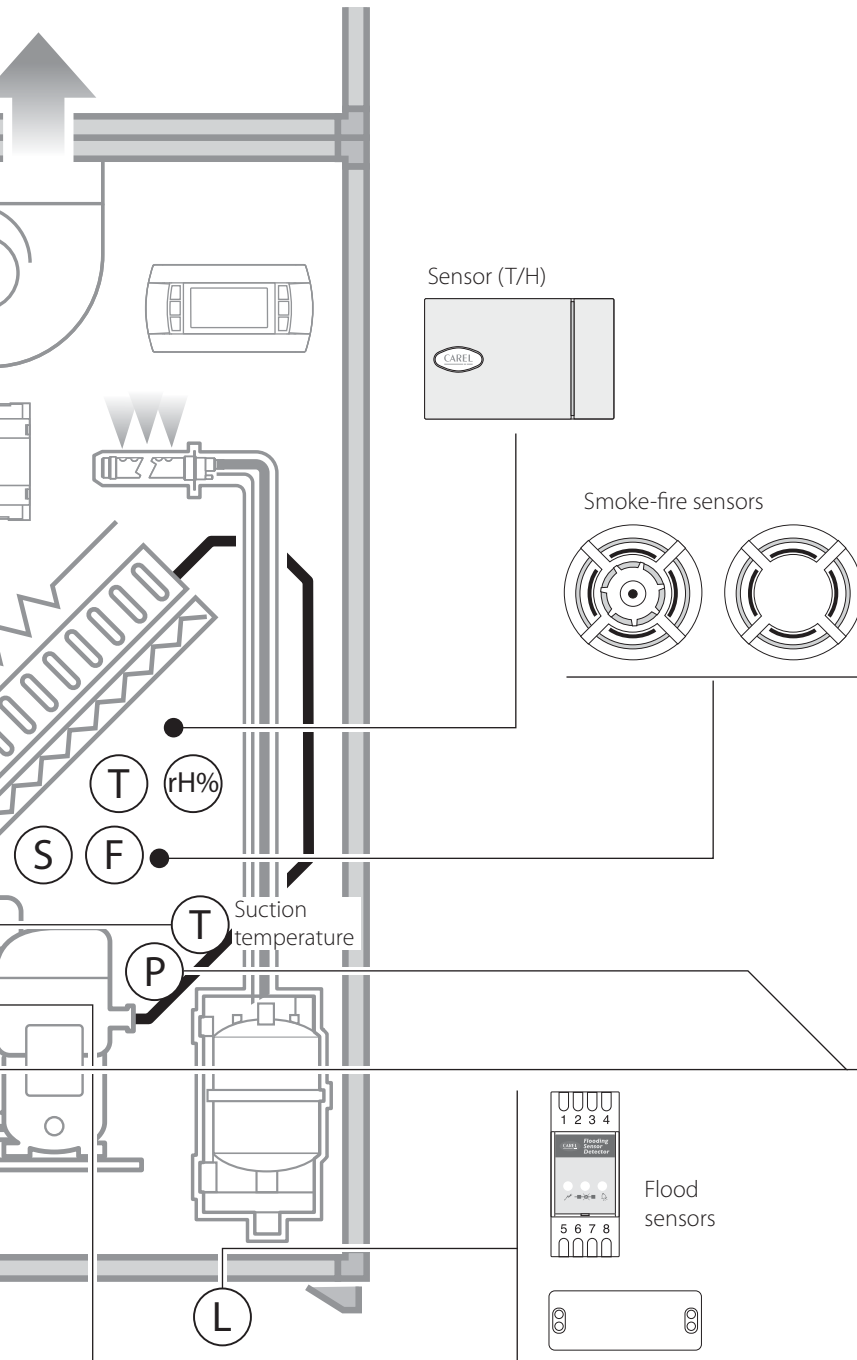

Connection with capillary

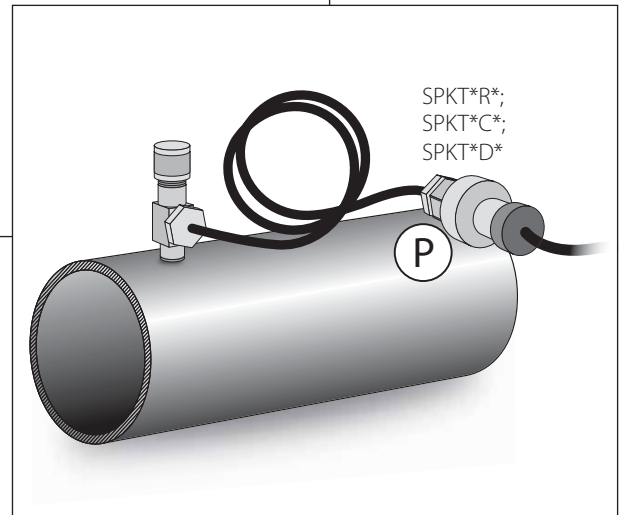

Welded connection

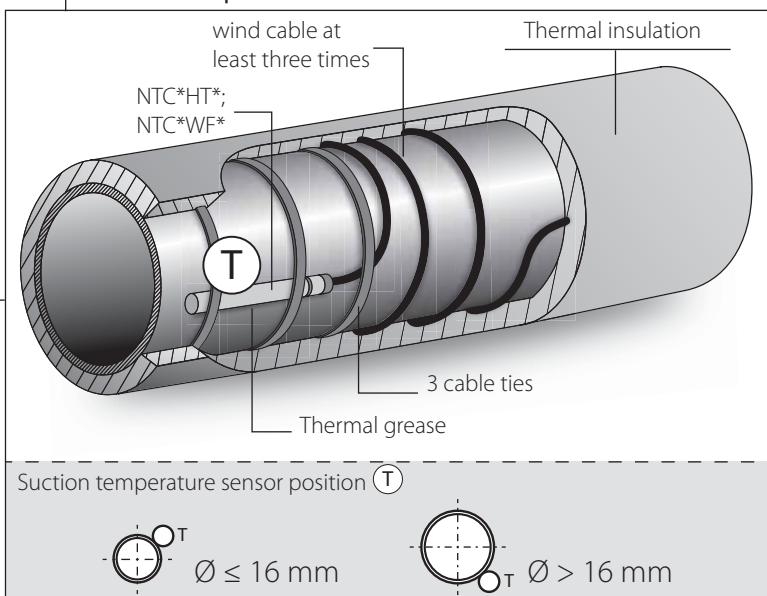
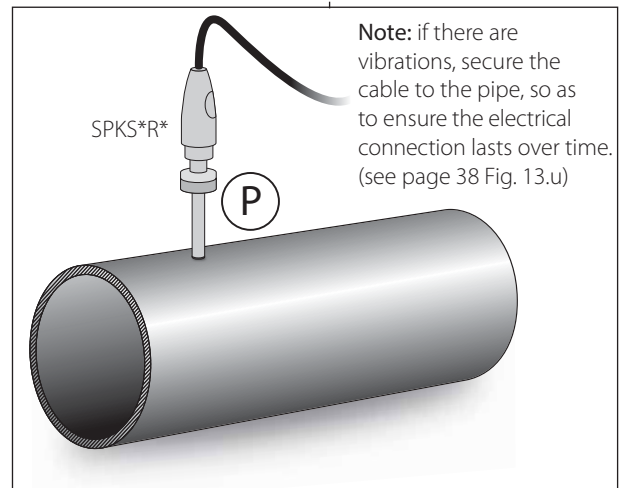



12.4 CRAC CW

KEY

<b>T</b>	Temperature
<b>rH%</b>	Relative humidity
<b>ΔP</b>	Differential pressure
<b>S</b>	Smoke
<b>F</b>	Fire
<b>L</b>	Flood sensor

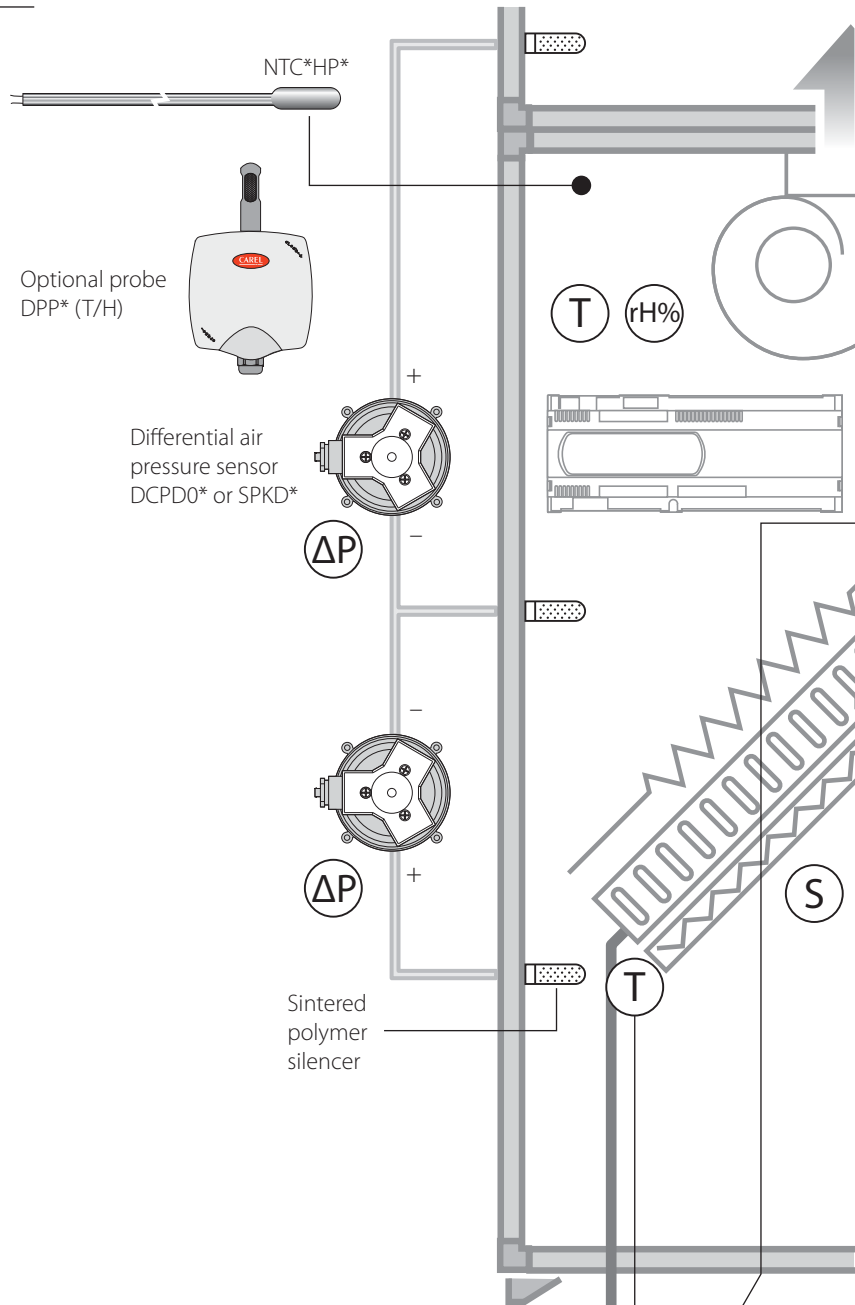

Control probe

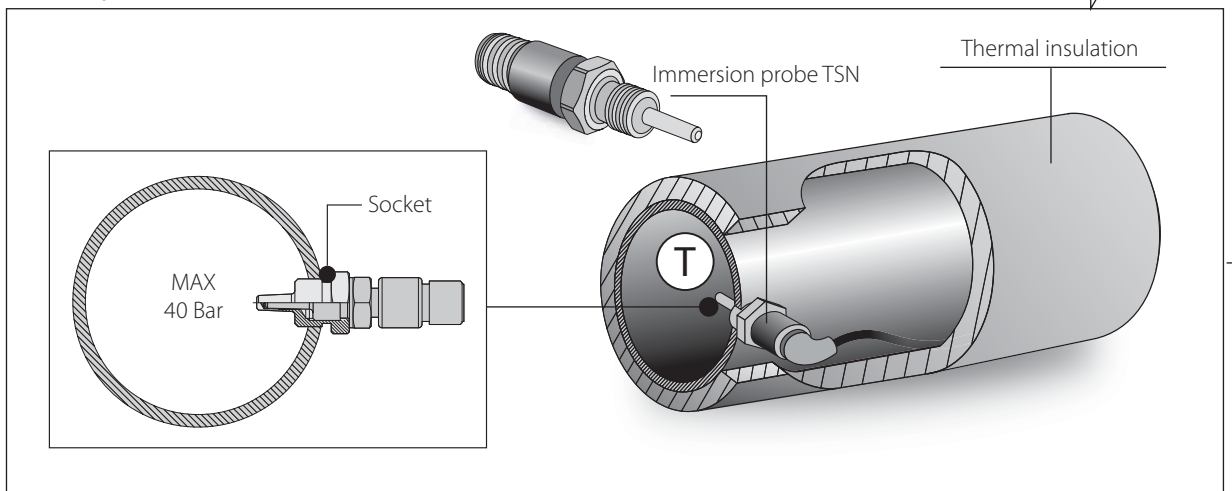

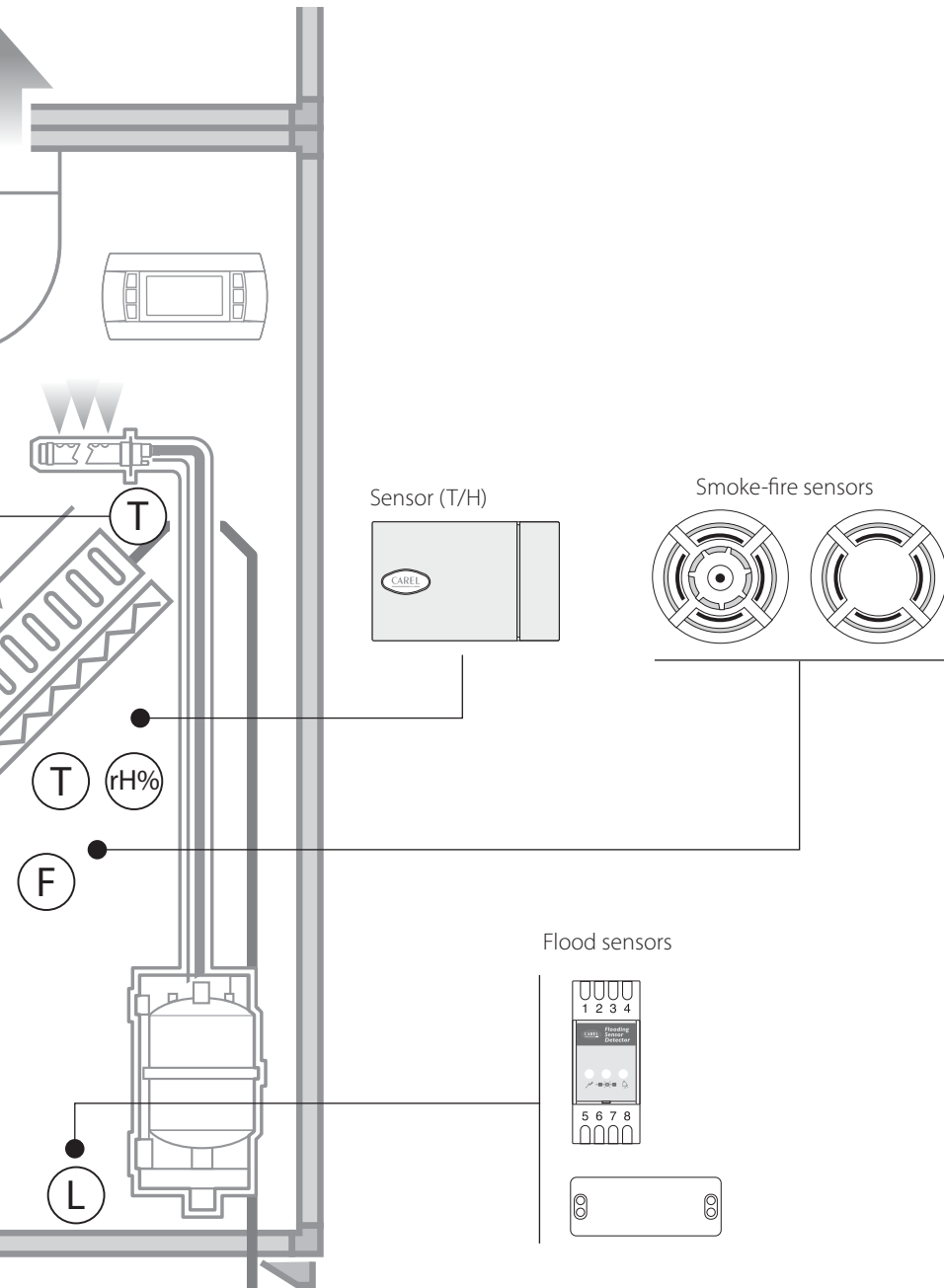

1st alternative solution - Reading probe

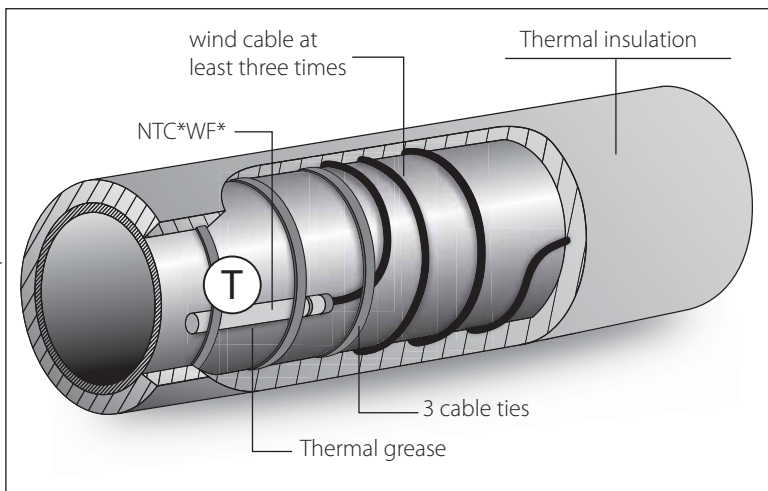

2nd alternative solution - Reading probe

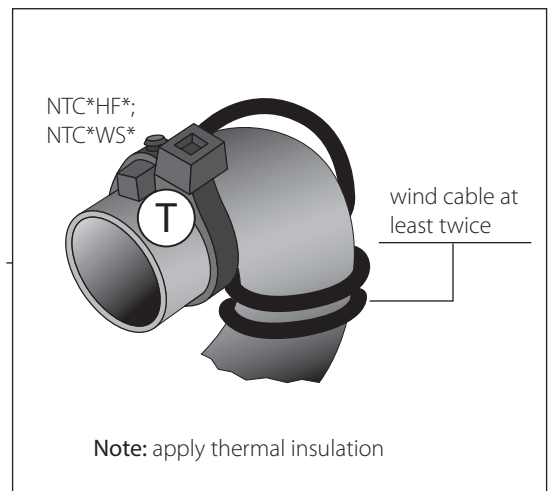

12.5 HVAC: Technological/process cooling application - Air/water chillers

KEY

<b>T</b>	Temperature
<b>P</b>	Pressure

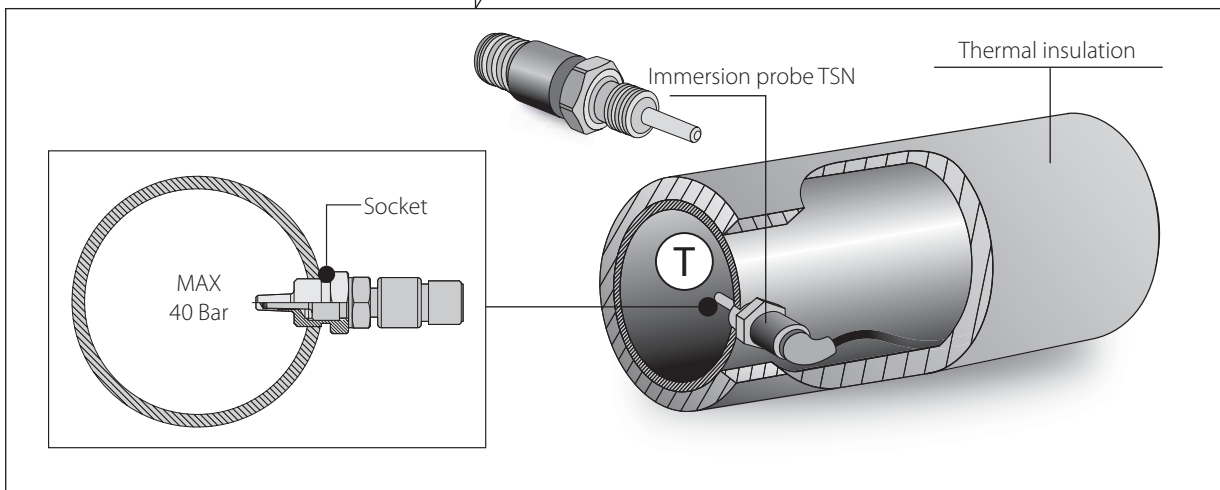
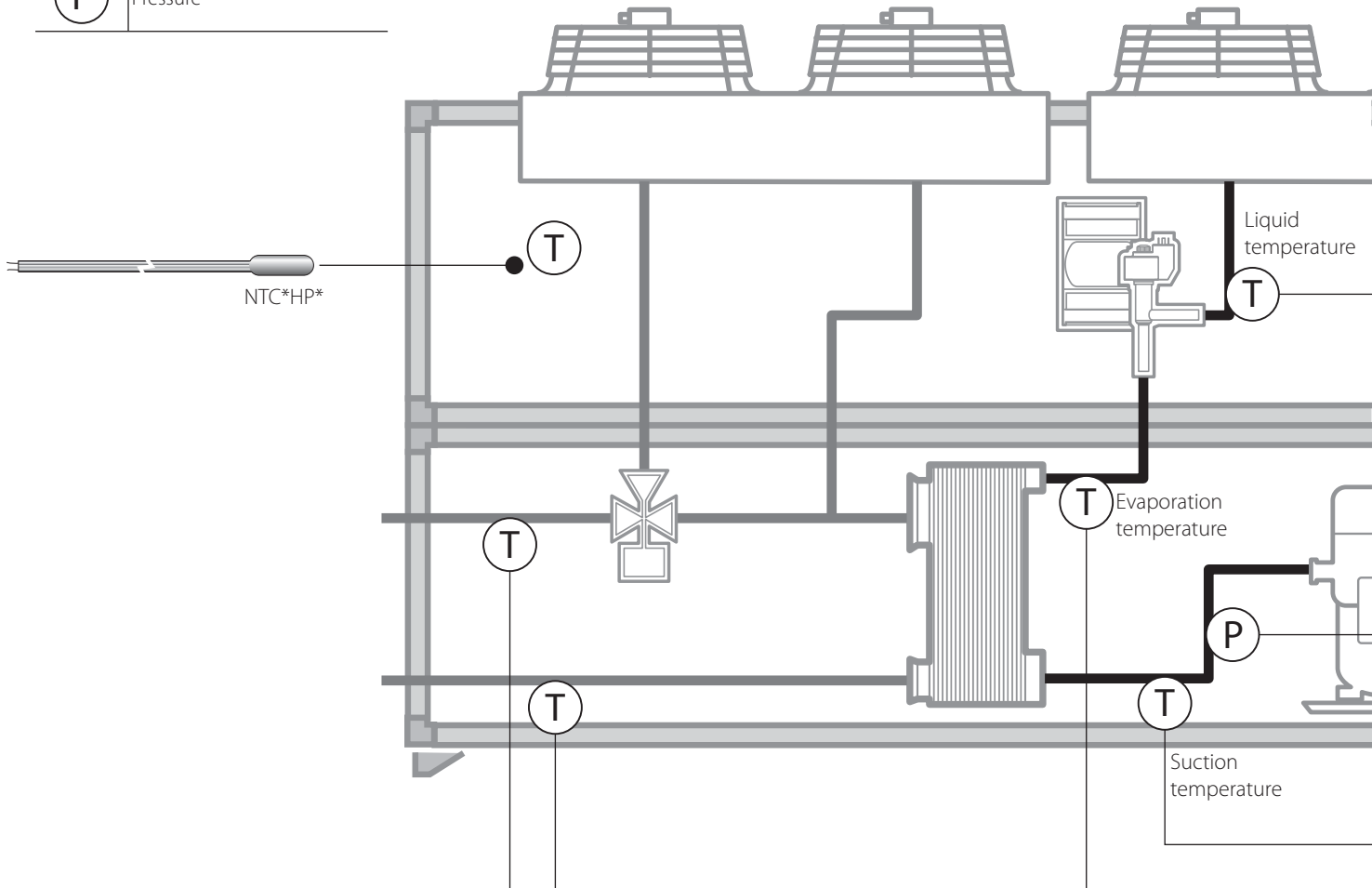

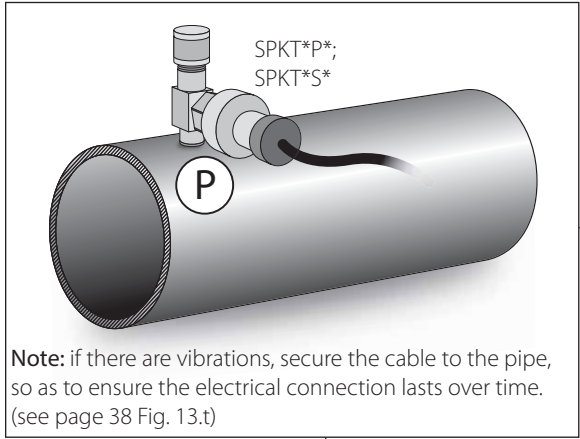

Connection with capillary

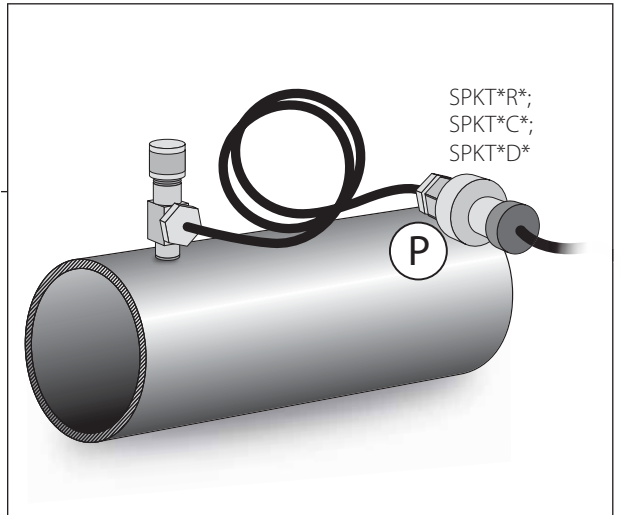

Welded connection

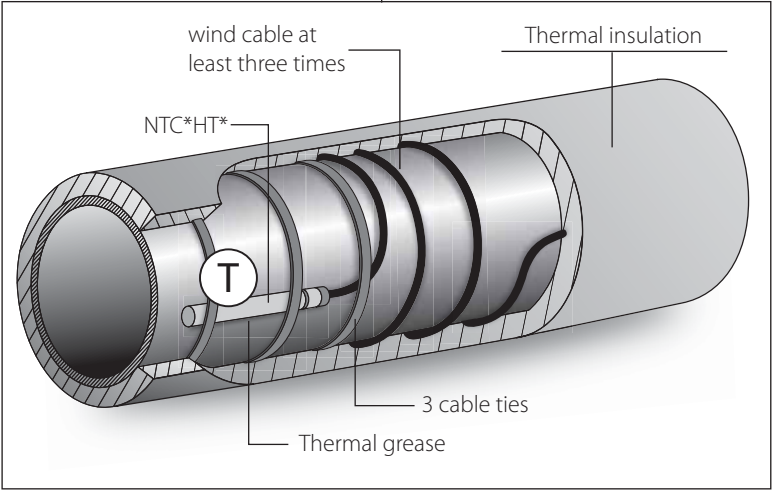
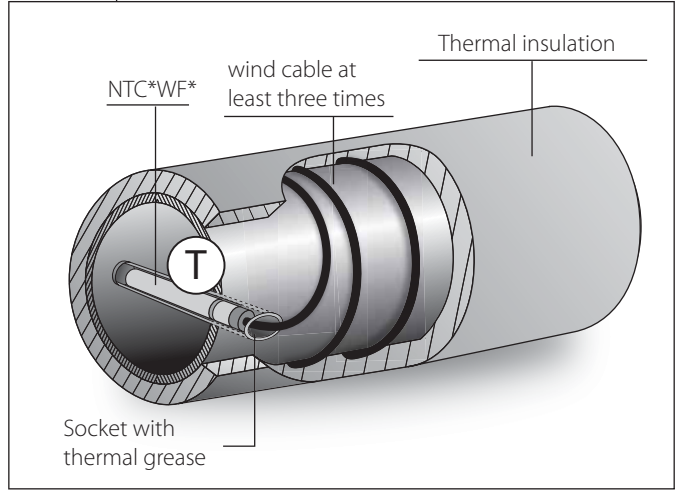
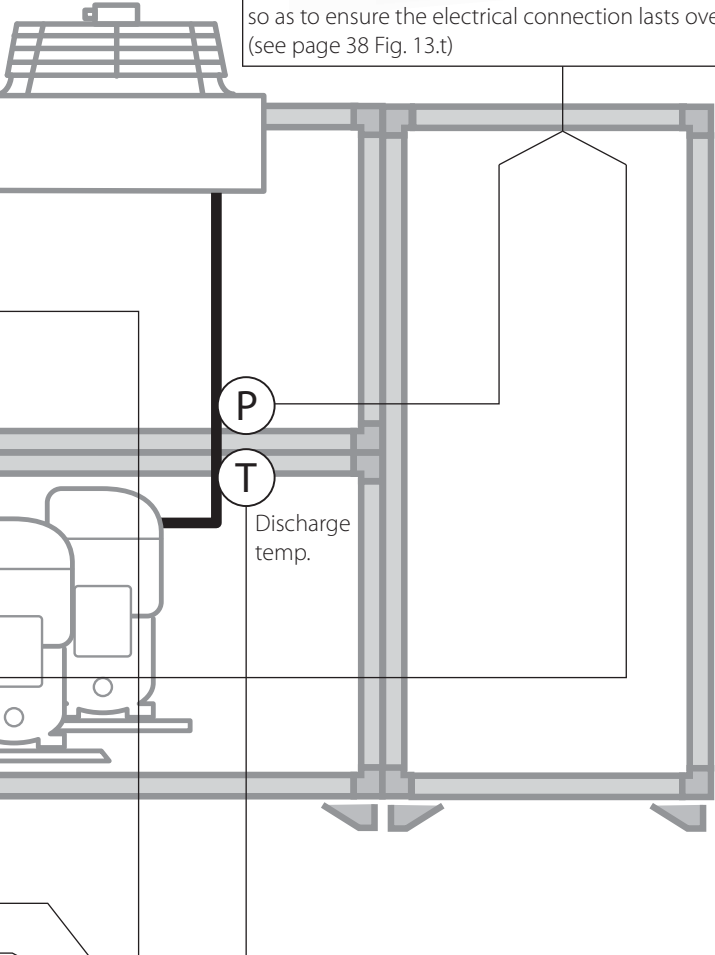
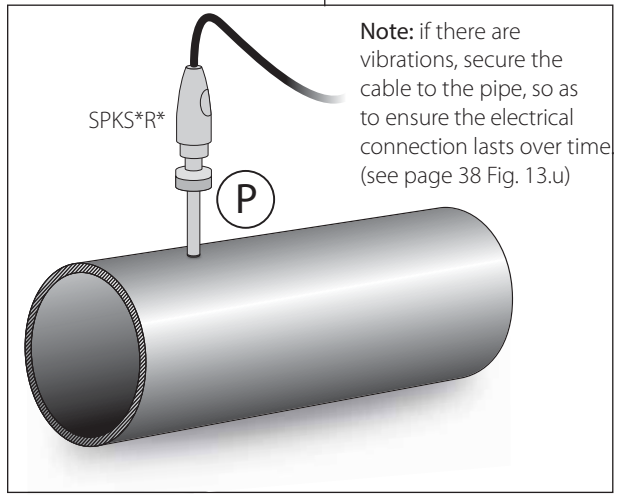

12.6 HVAC: Commercial/residential applications - Rooftop

KEY

$T$	Temperature
$P$	Pressure
rH%	Relative humidity
$\Delta P$	Differential pressure

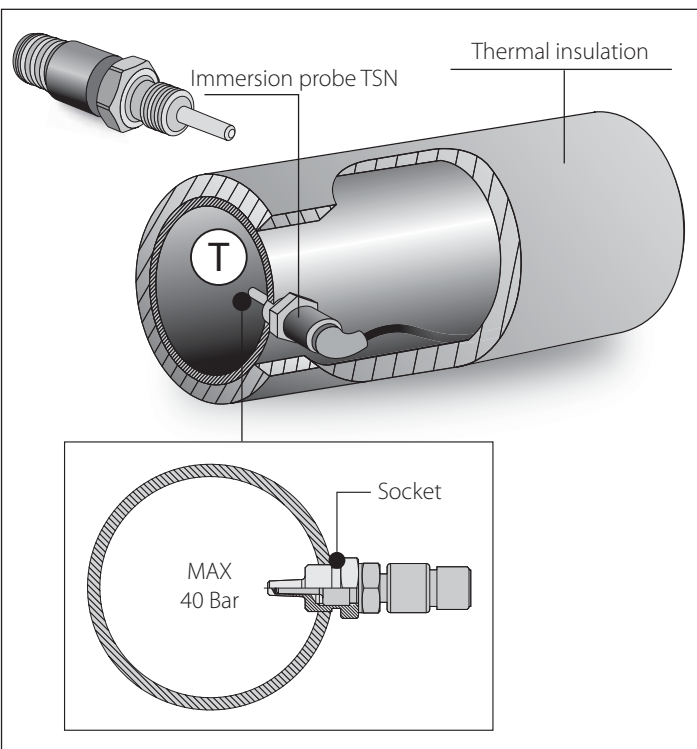
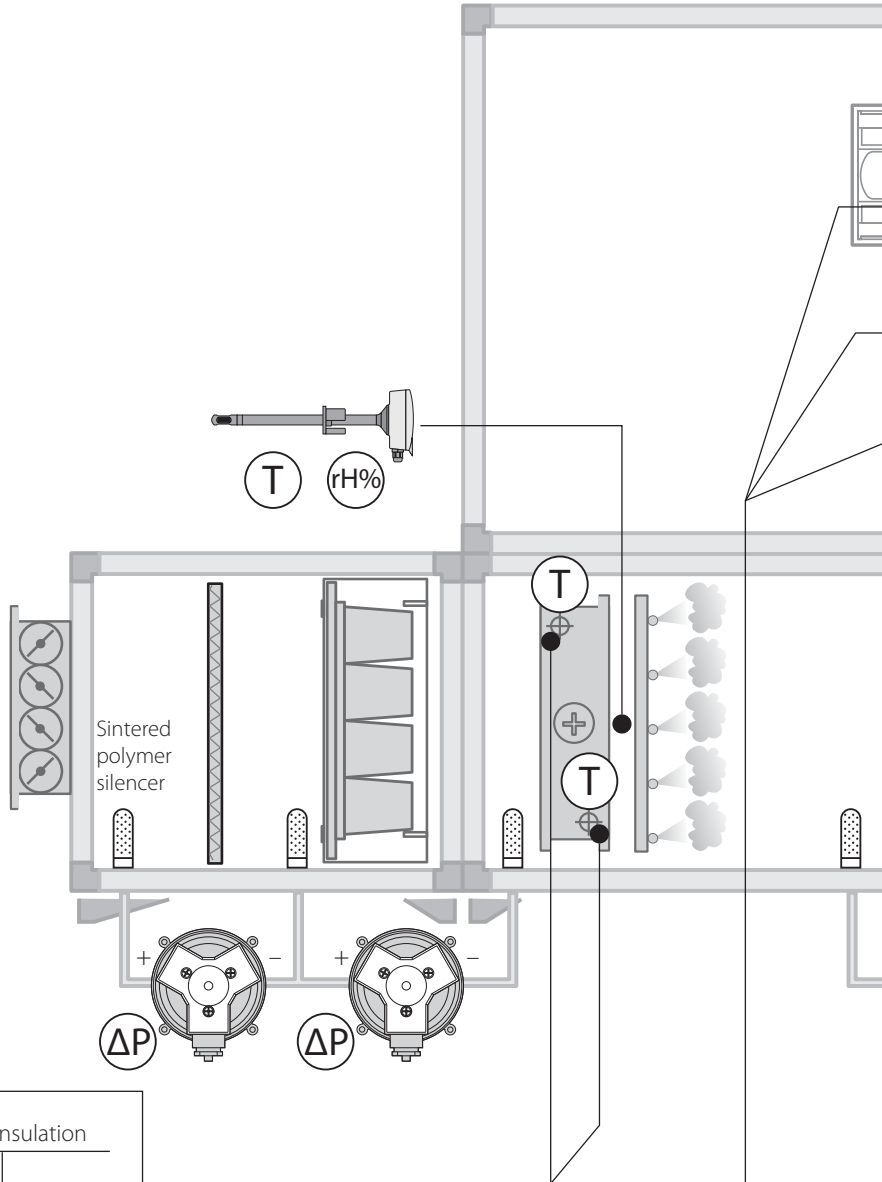
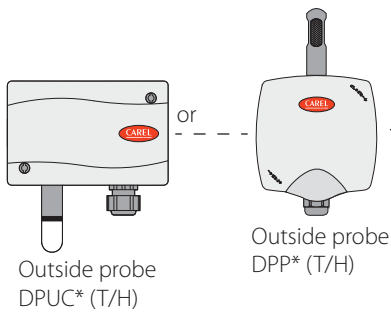

BLDC compressor

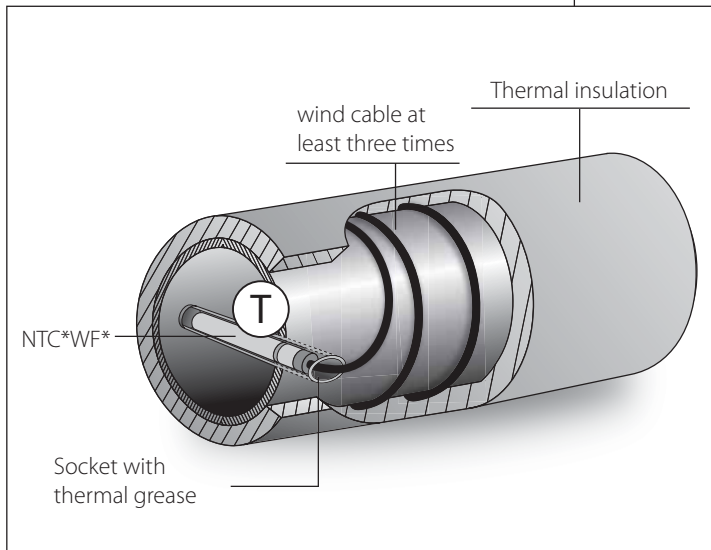

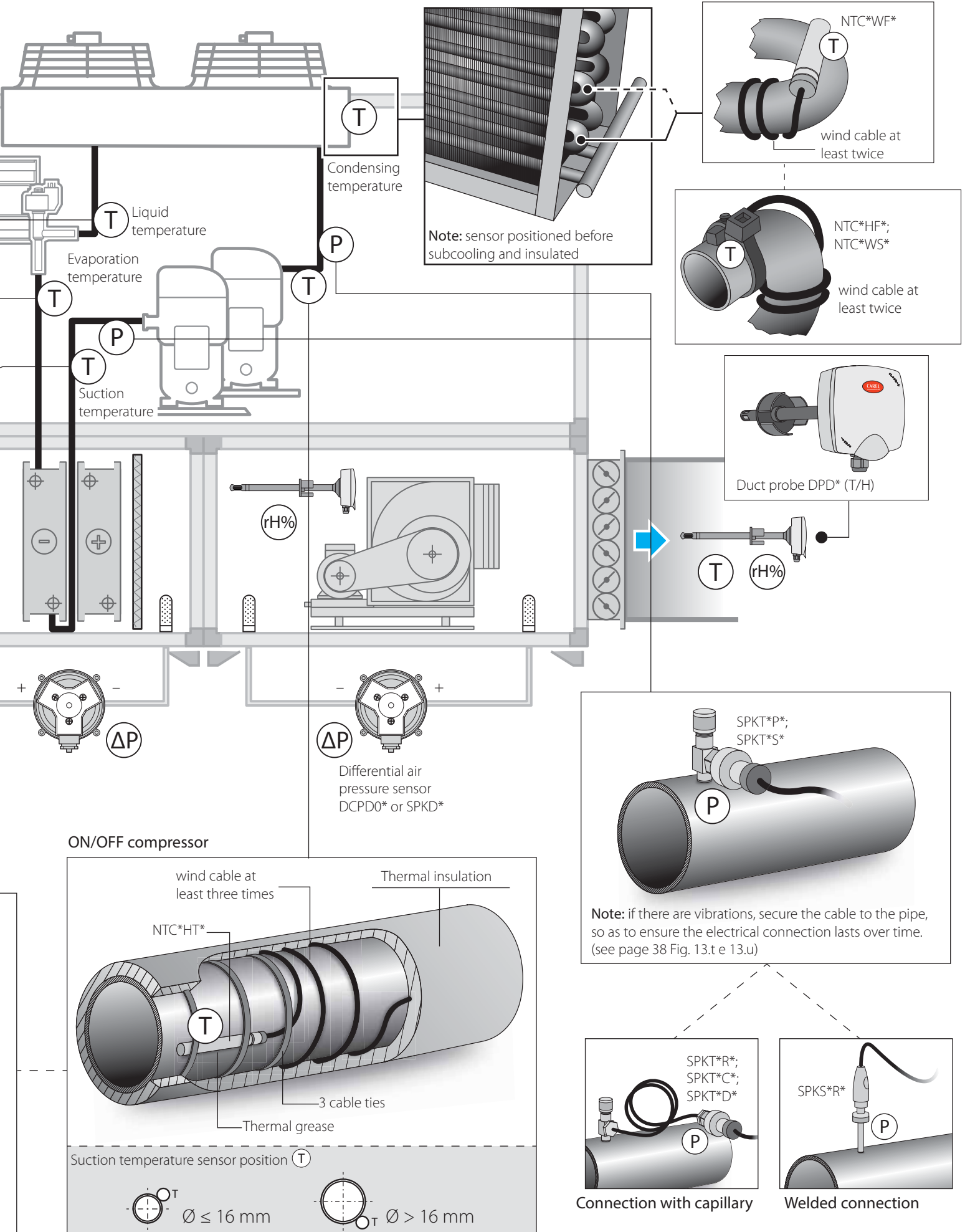

12.7 Blast chillers/freezers

KEY

<b>T</b>	Temperature
<b>P</b>	Pressure
<b>rH%</b>	Relative humidity

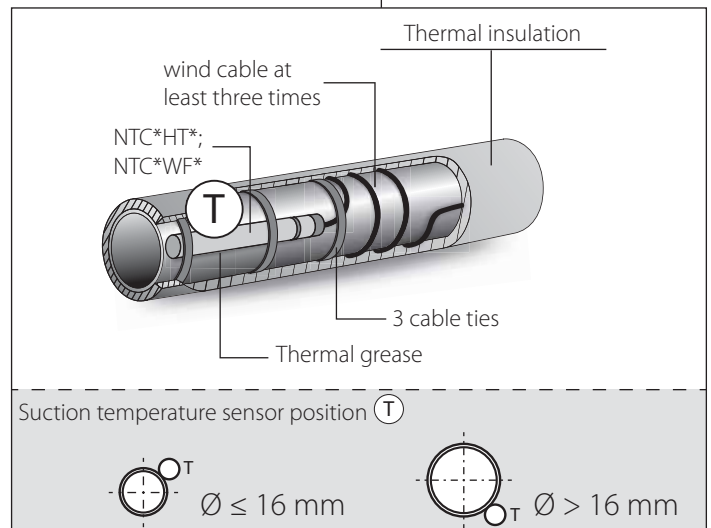
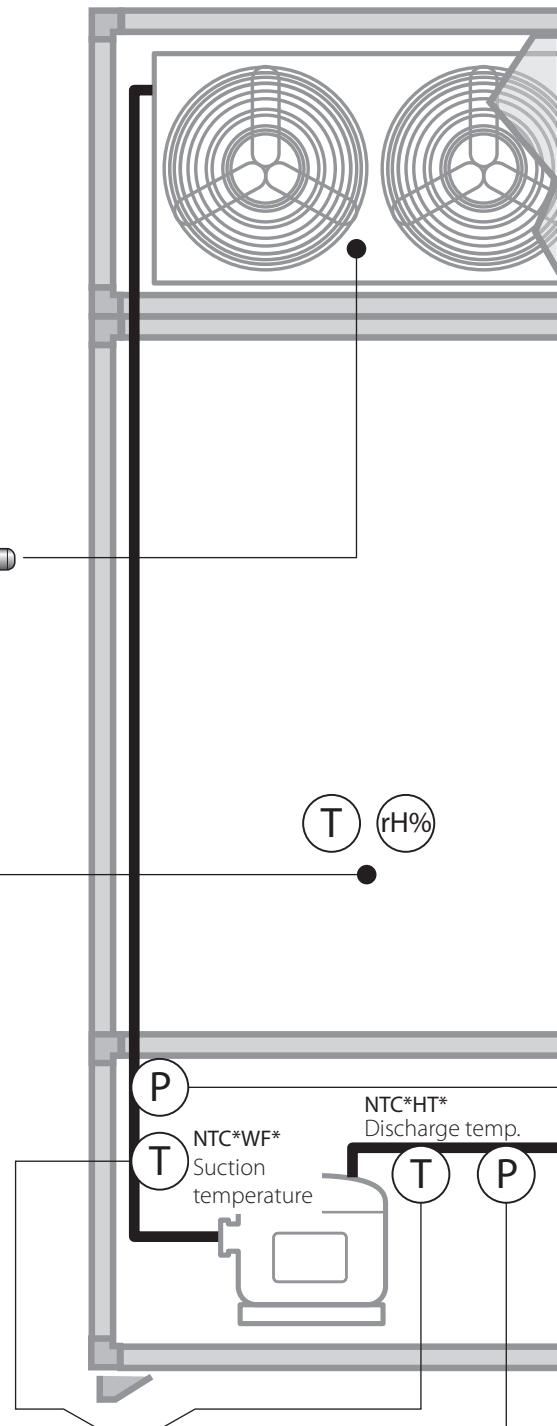
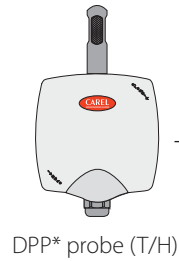
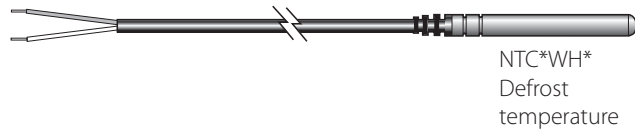

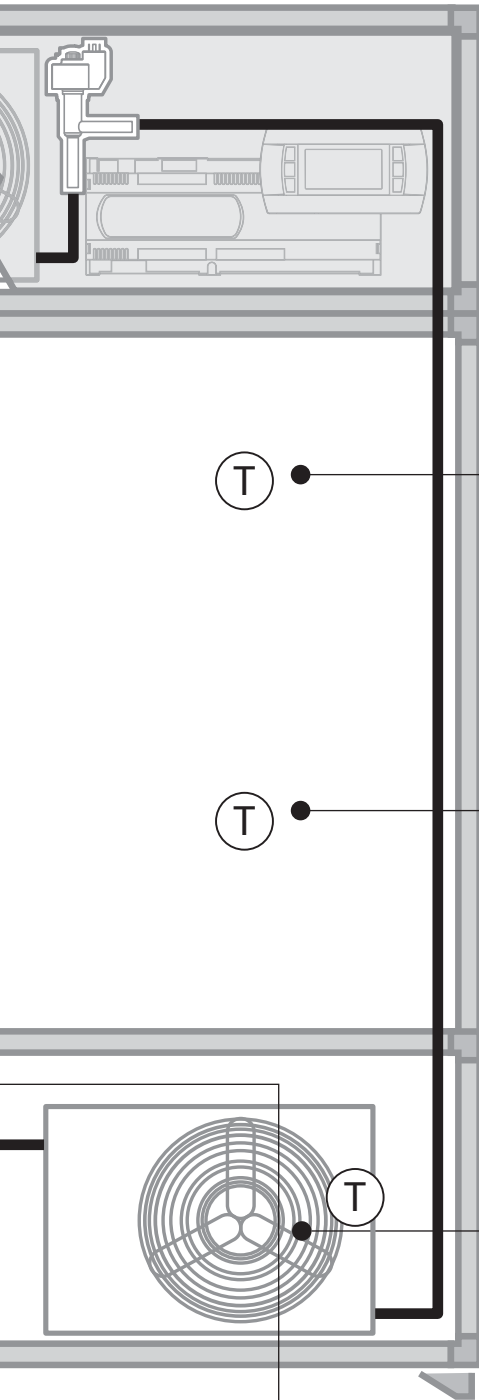

Piercing probe NTCINF610\*  
Product temperature

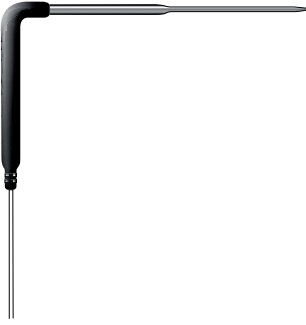

T

NTC\*HP\*;  
NTC\*HF\*;  
NTC\*WS\*



Cold room  
temperature

T

Welded connection

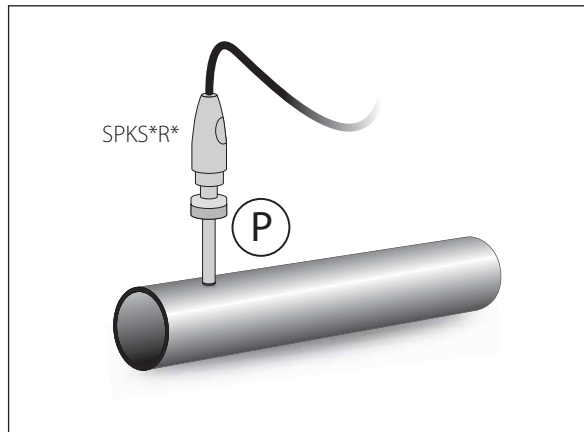

SPKS\*R\*

P

Condensing  
temperature

T

Connection with capillary

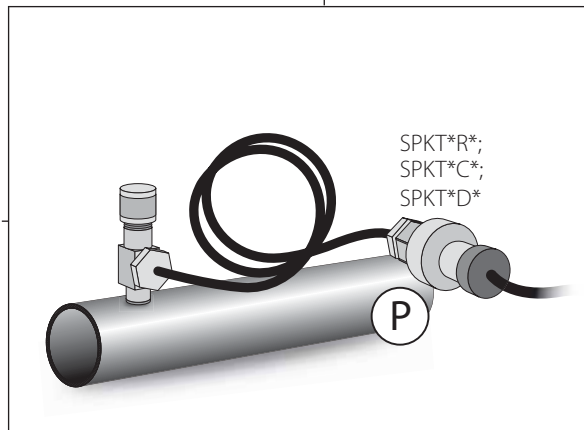

SPKT\*R\*;  
SPKT\*C\*;  
SPKT\*D\*

P

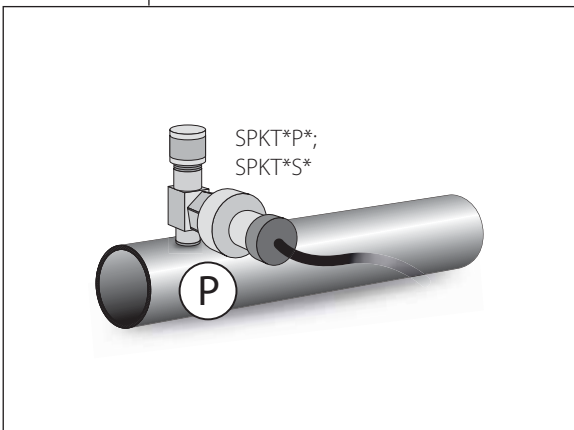

SPKT\*P\*;  
SPKT\*S\*

P



12.8 Stand-alone showcases/bottle coolers

KEY

T	Temperature
P	Pressure

Welded connection

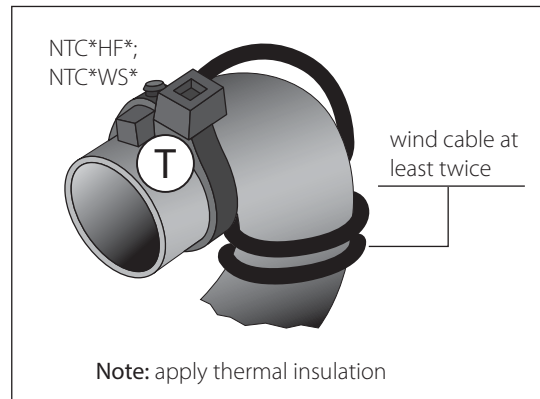
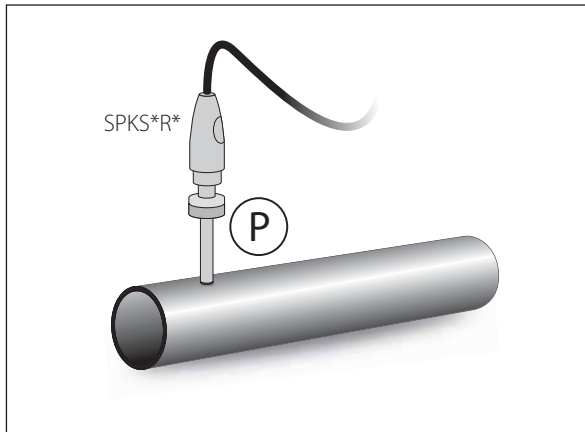

Connection with capillary

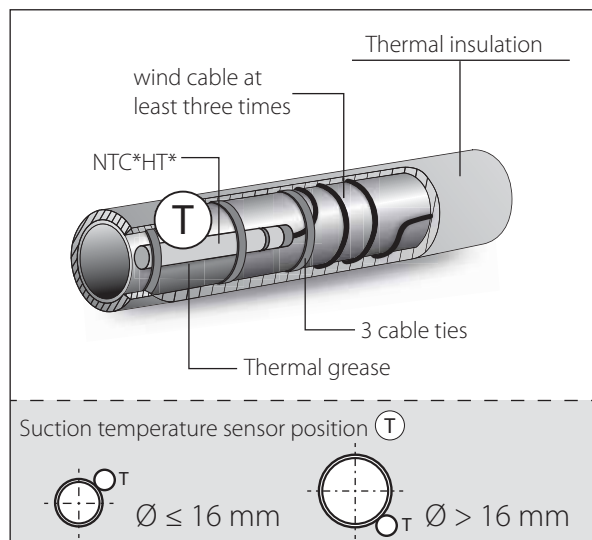
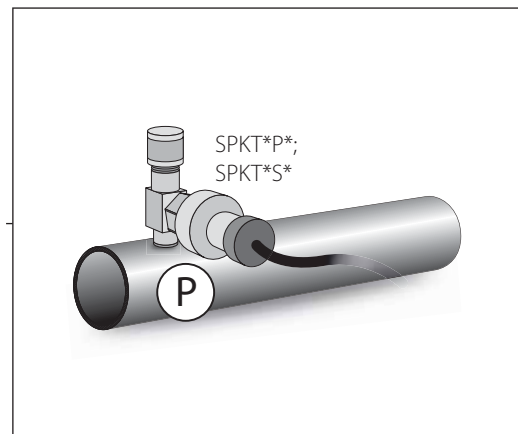
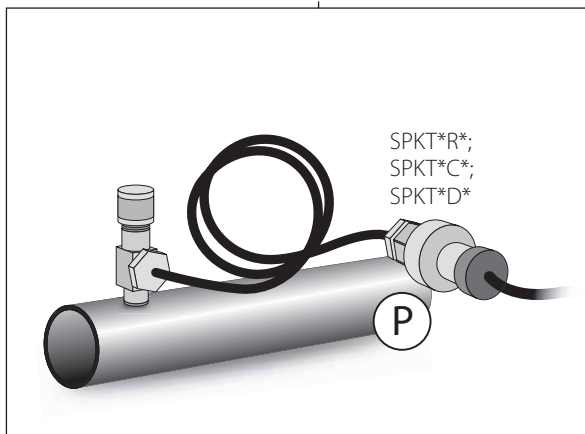

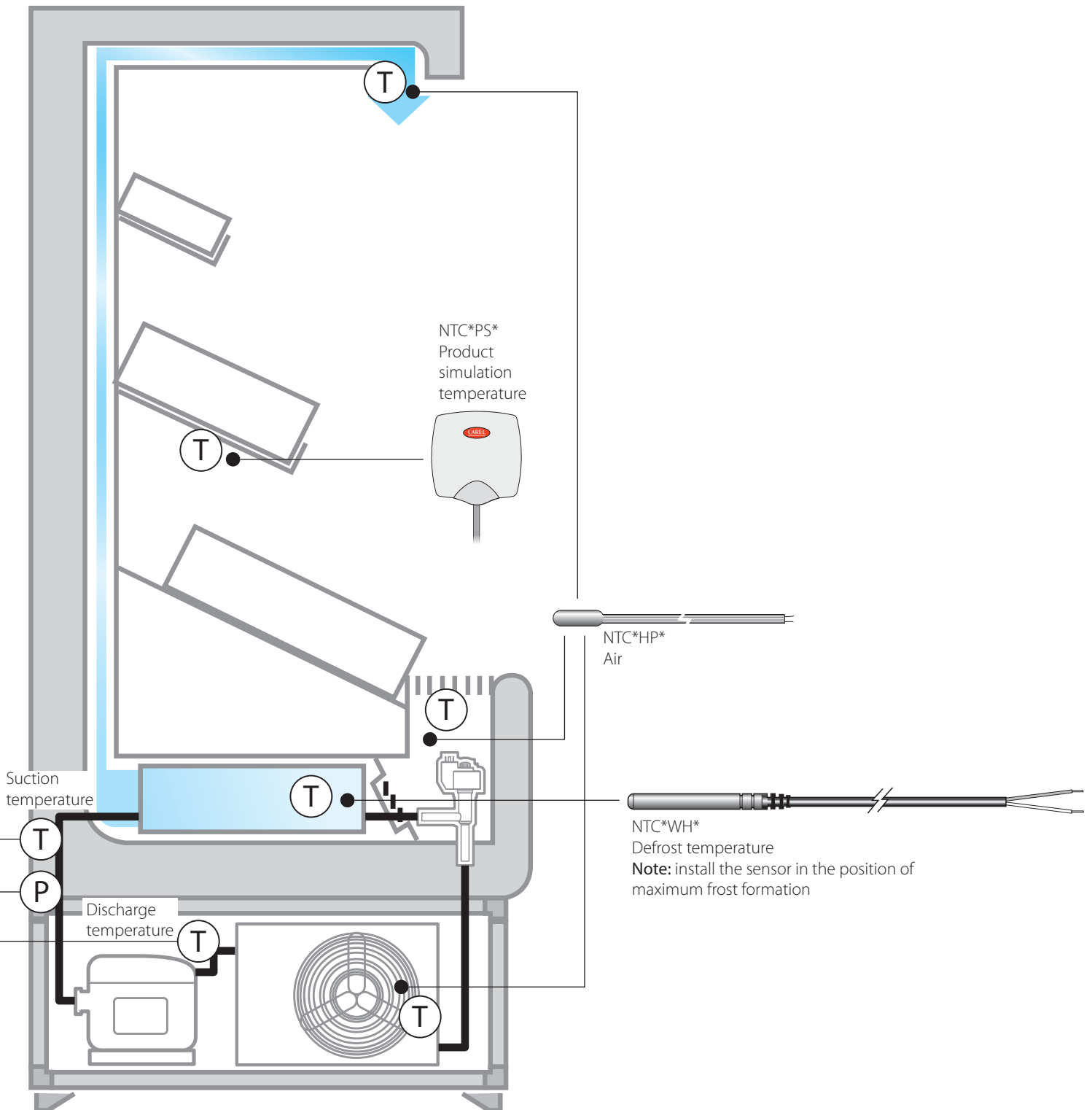

12.9 Water-cooled stand-alone showcases

KEY

<b>T</b>	Temperature
<b>rH%</b>	Relative humidity
<b>P</b>	Pressure

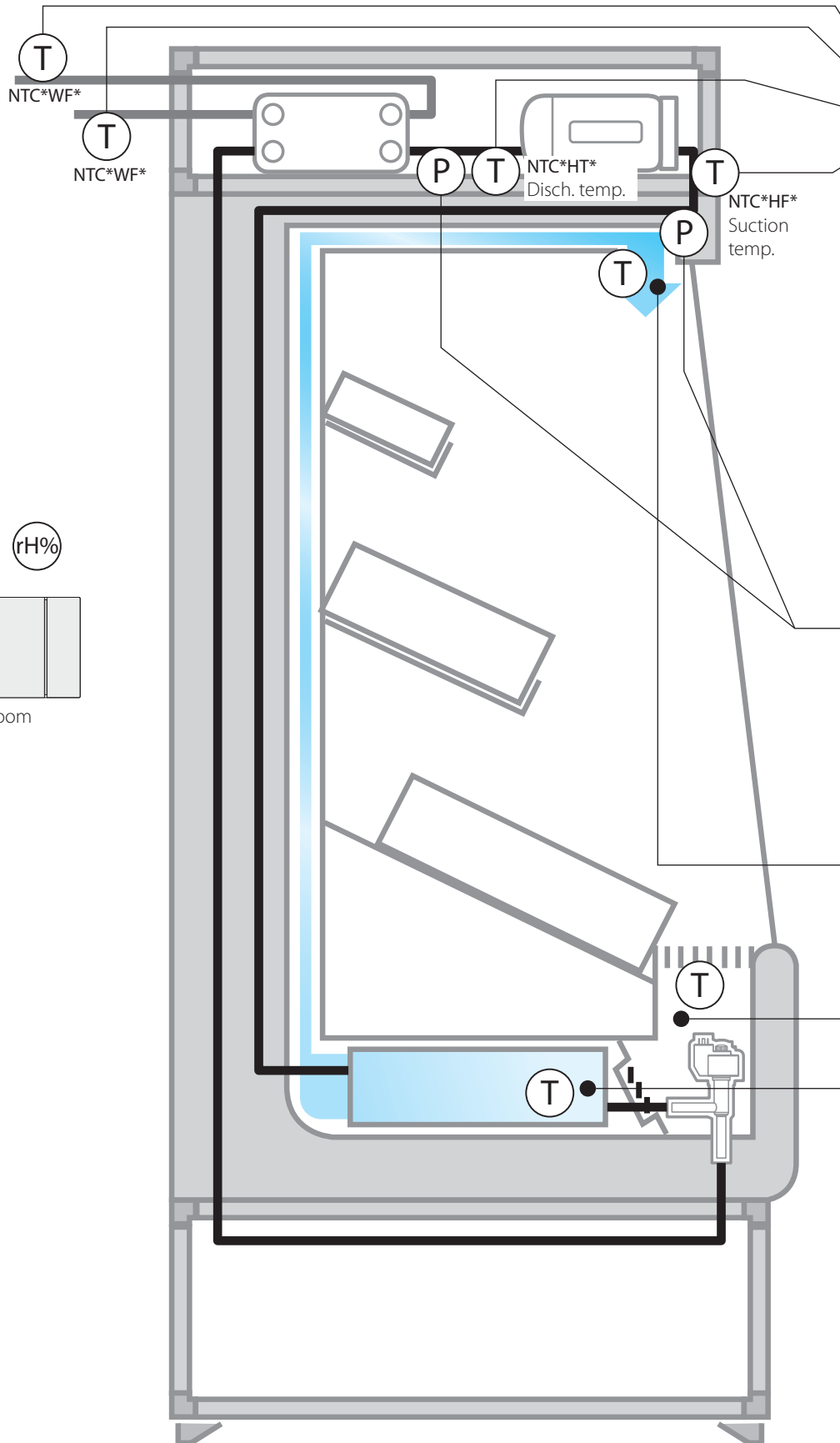
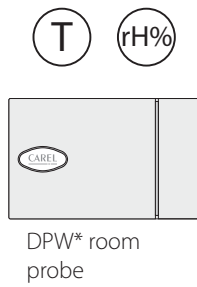

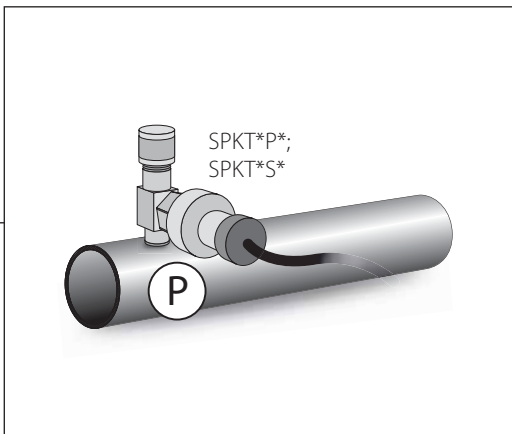
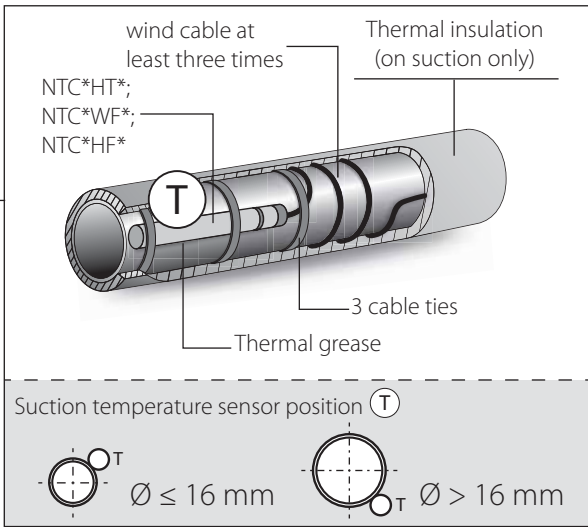

Connection with capillary

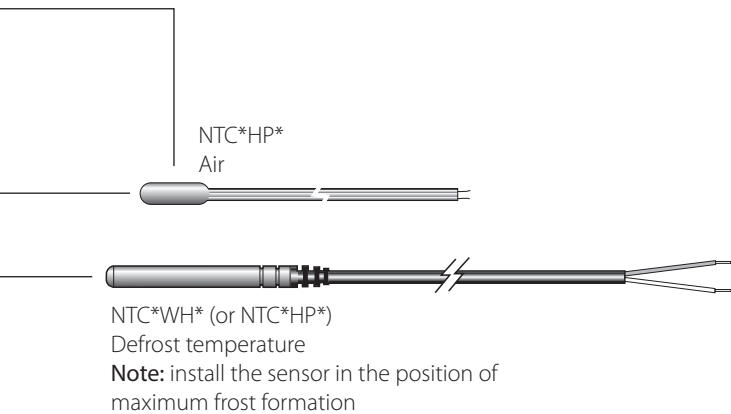
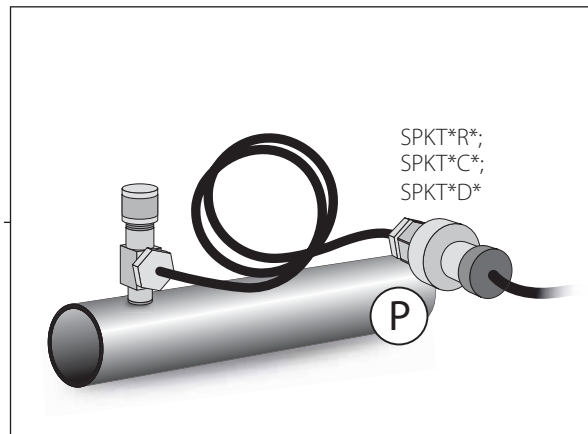

Welded connection

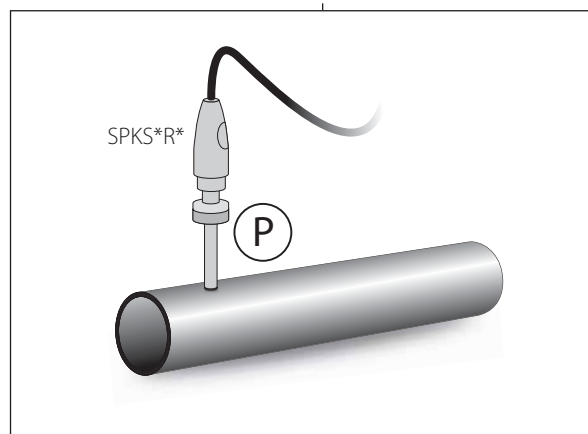

12.10 Centralised/multiplexed cabinets

KEY

<b>T</b>	Temperature
<b>P</b>	Pressure

Welded connection

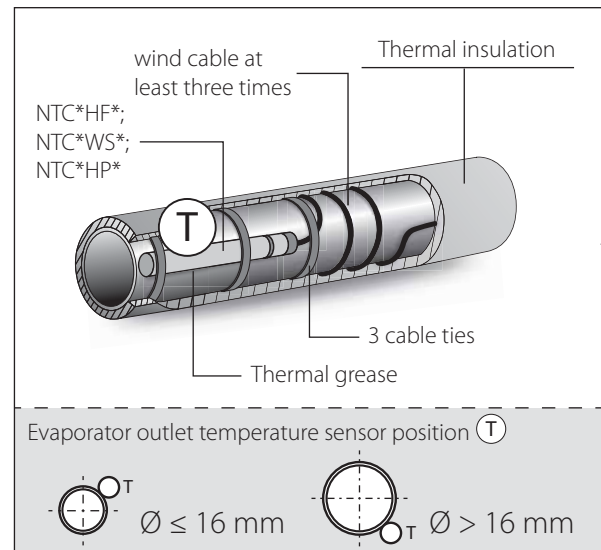
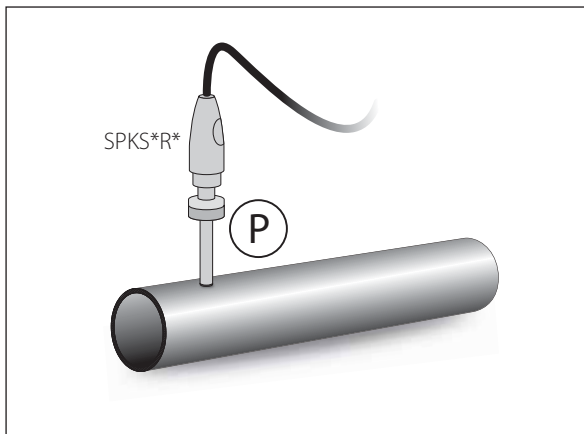

Connection with capillary

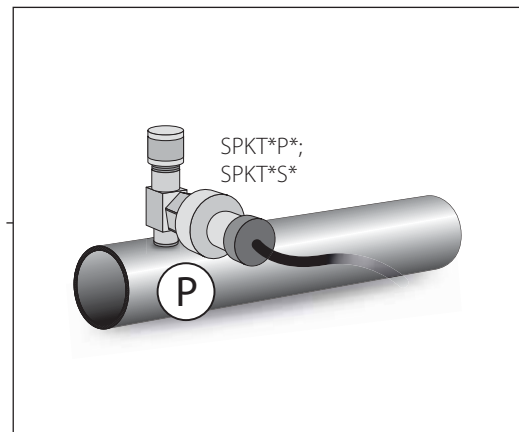
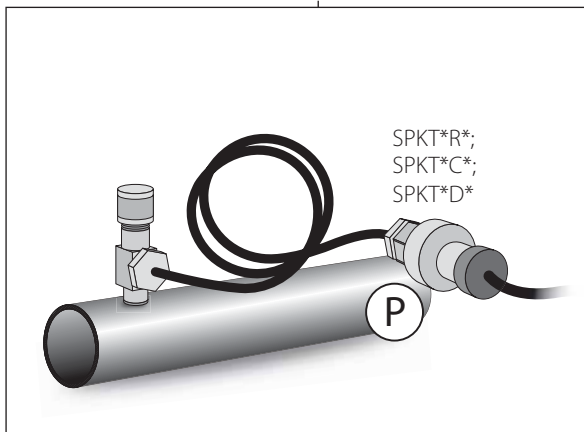

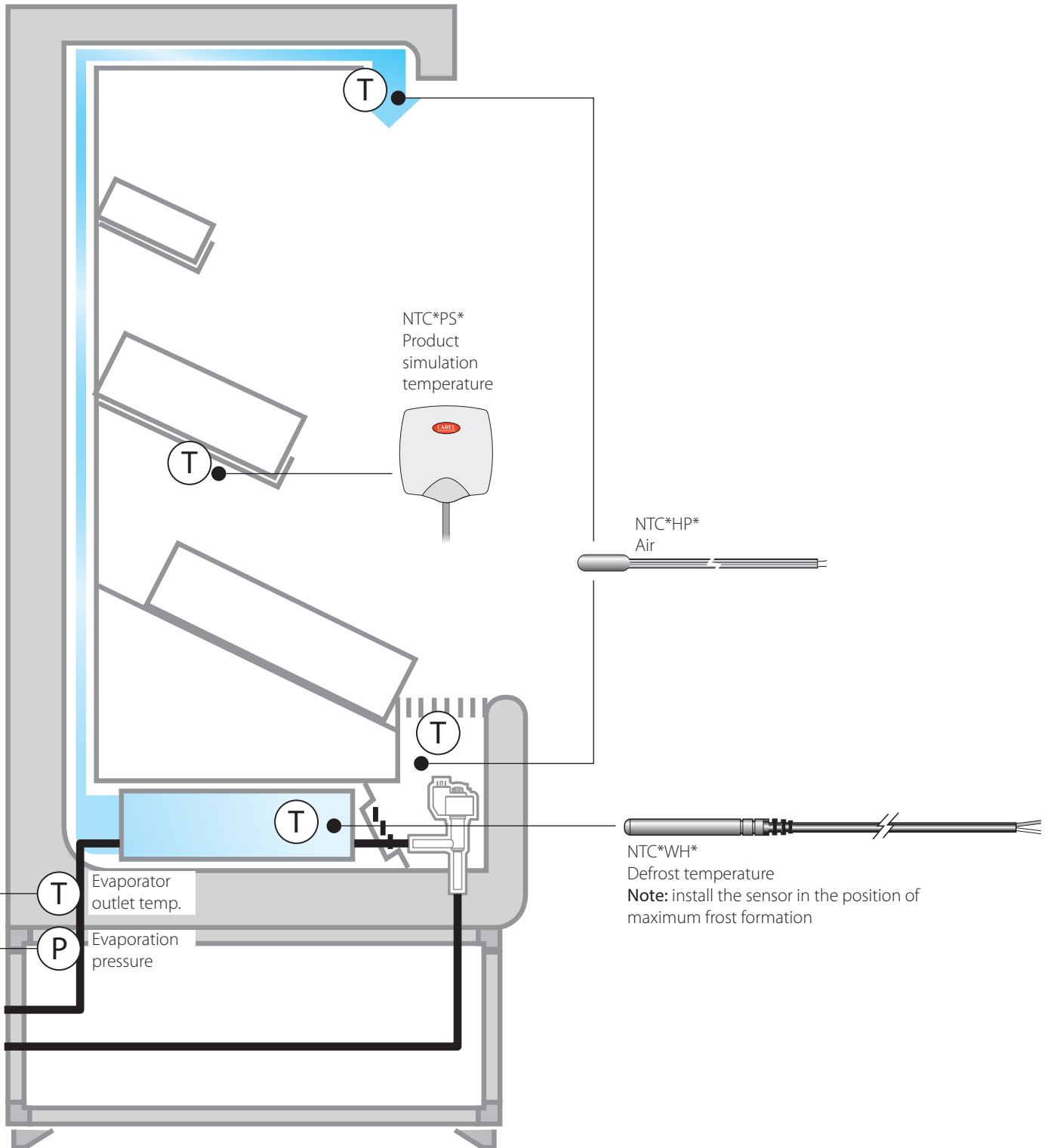

12.11 Cold rooms

KEY

T	Temperature
P	Pressure
rH%	Relative humidity

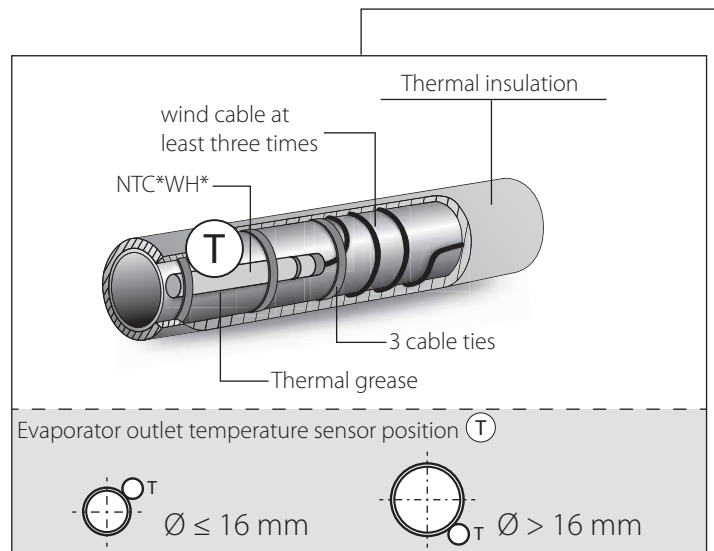
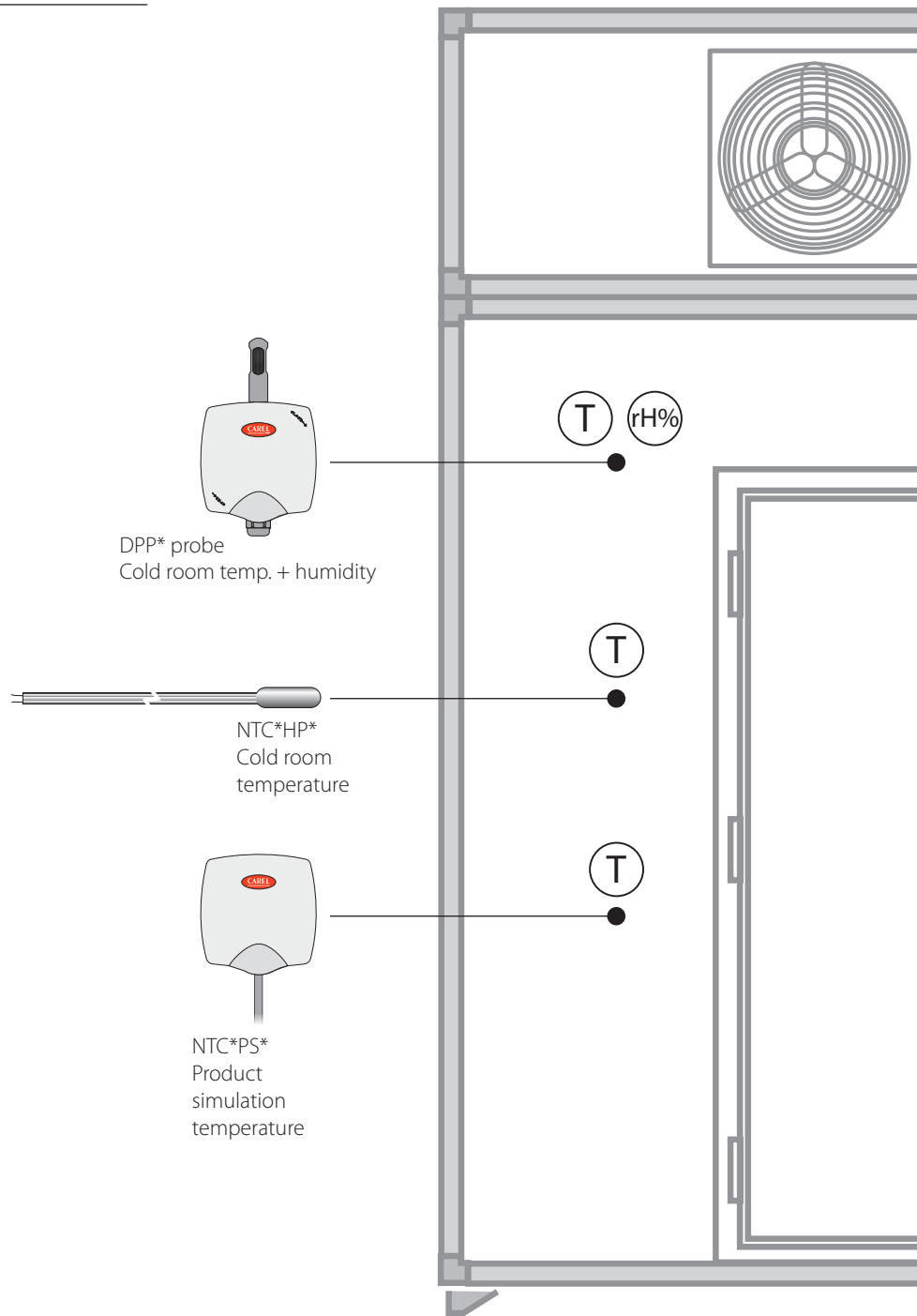

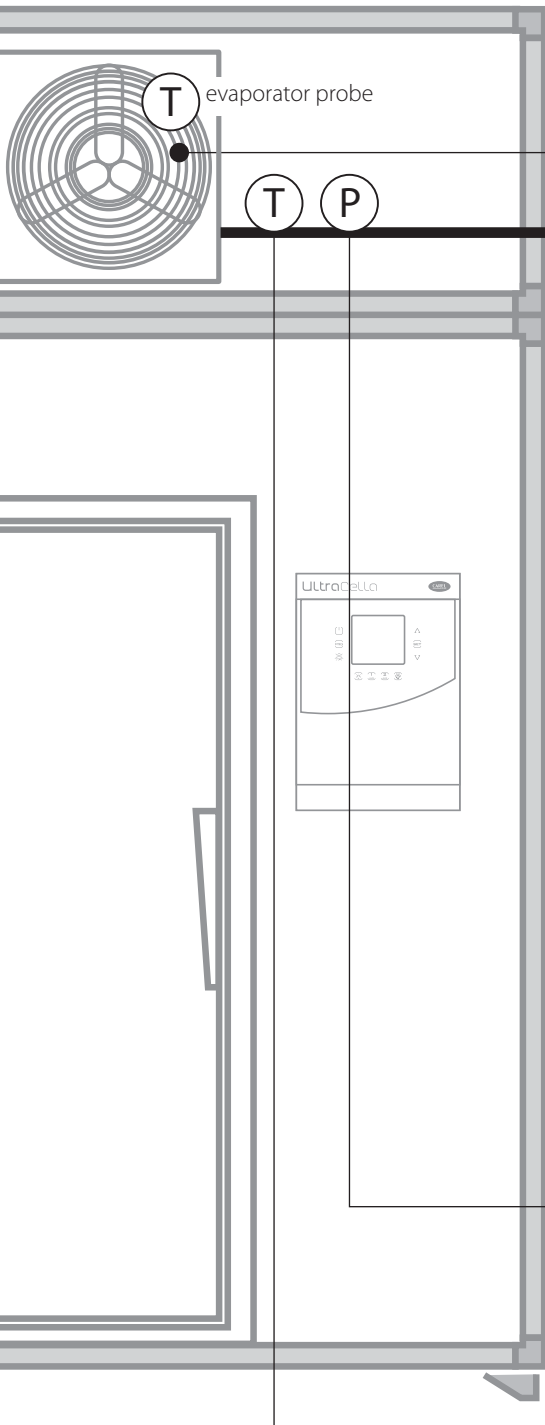

NTC\*WH\*  
 Defrost temperature  
**Note:** install the sensor in the position of maximum frost formation

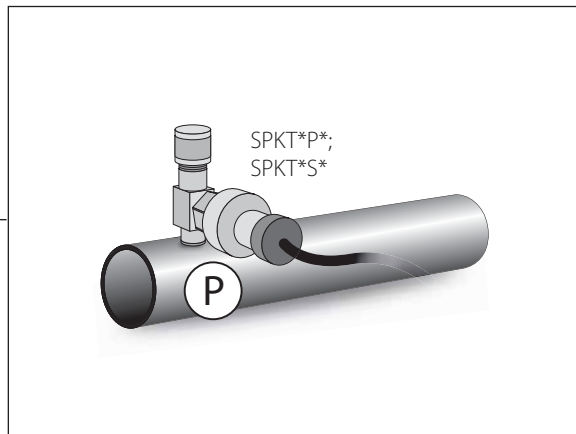
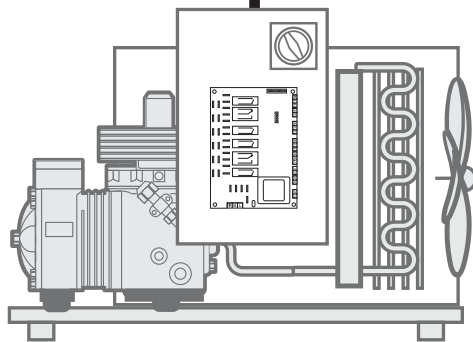

Welded connection

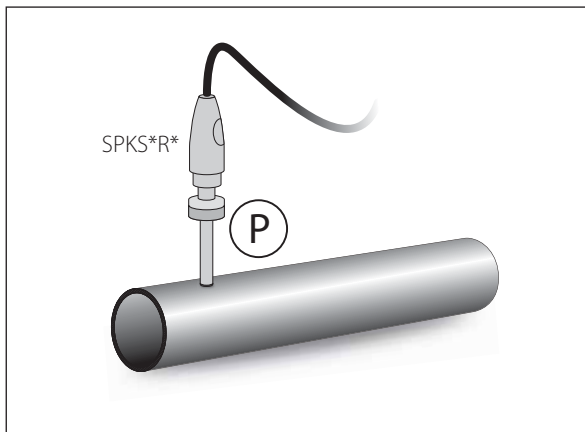

Connection with capillary

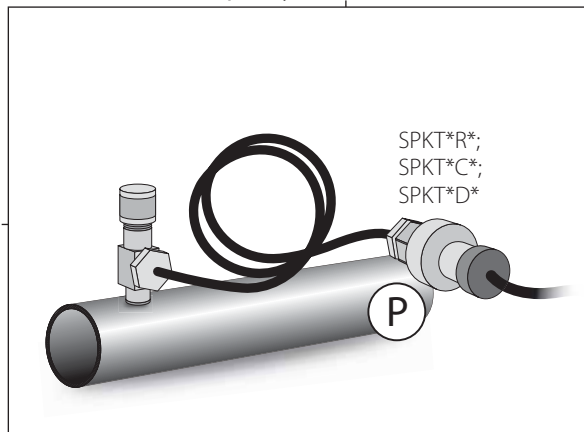



12.12 Transcritical CO<sub>2</sub> systems

KEY

T	Temperature
P	Pressure

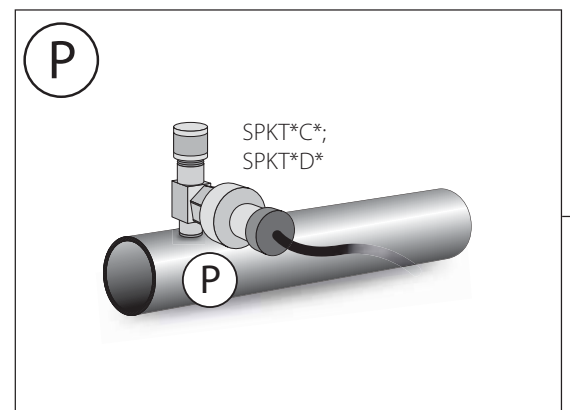
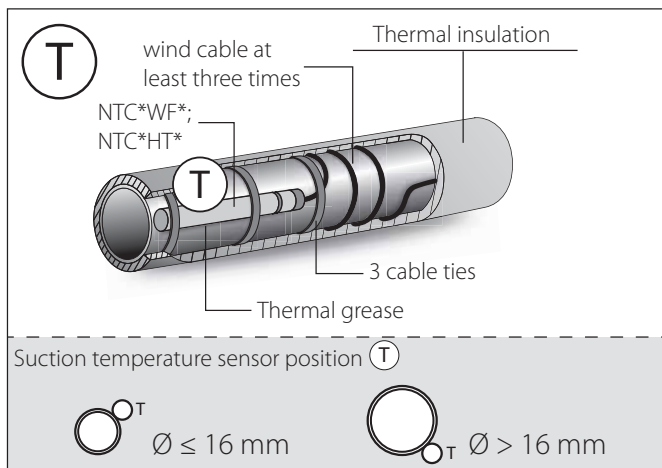
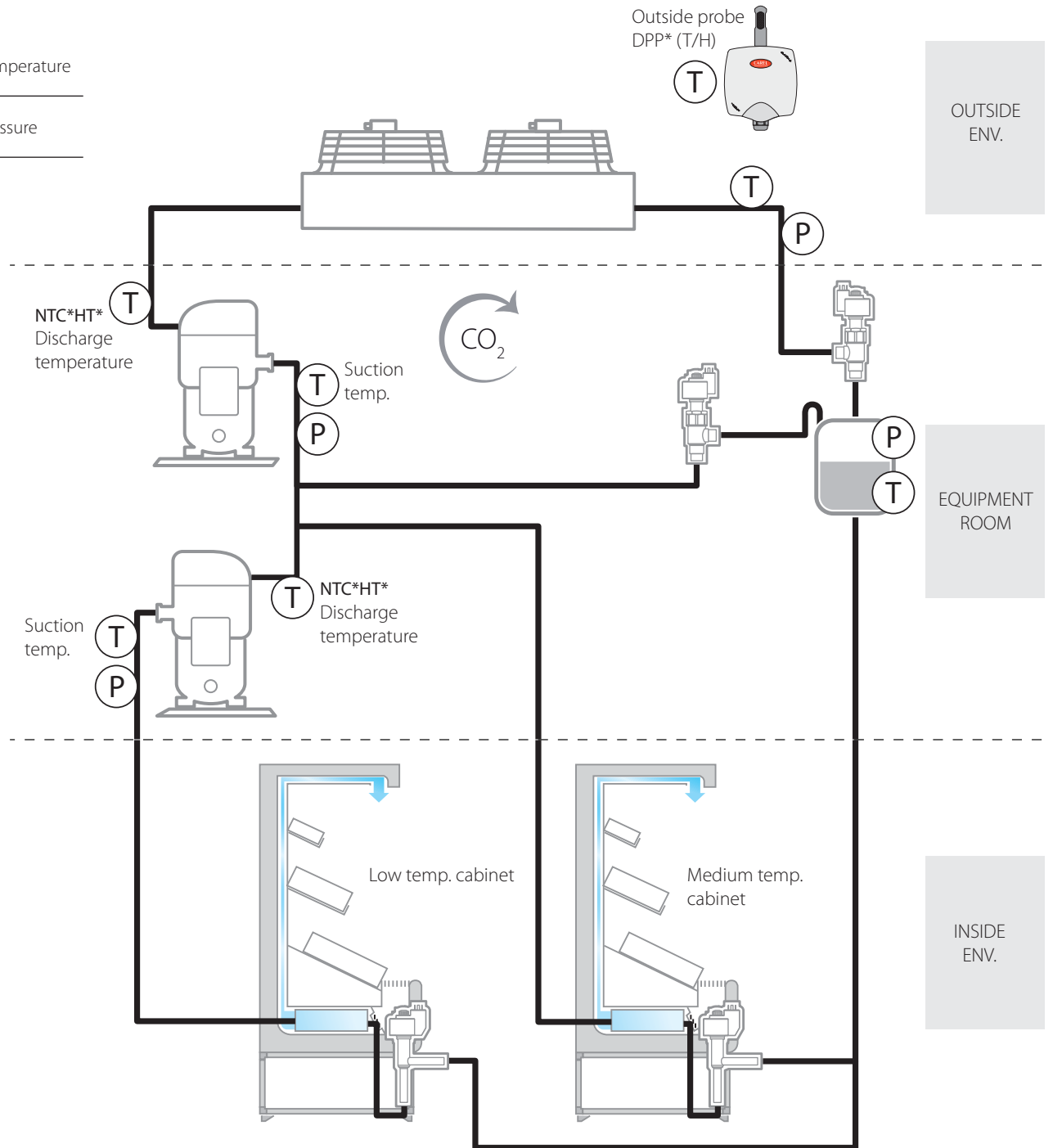

12.13 Subcritical CO<sub>2</sub> systems

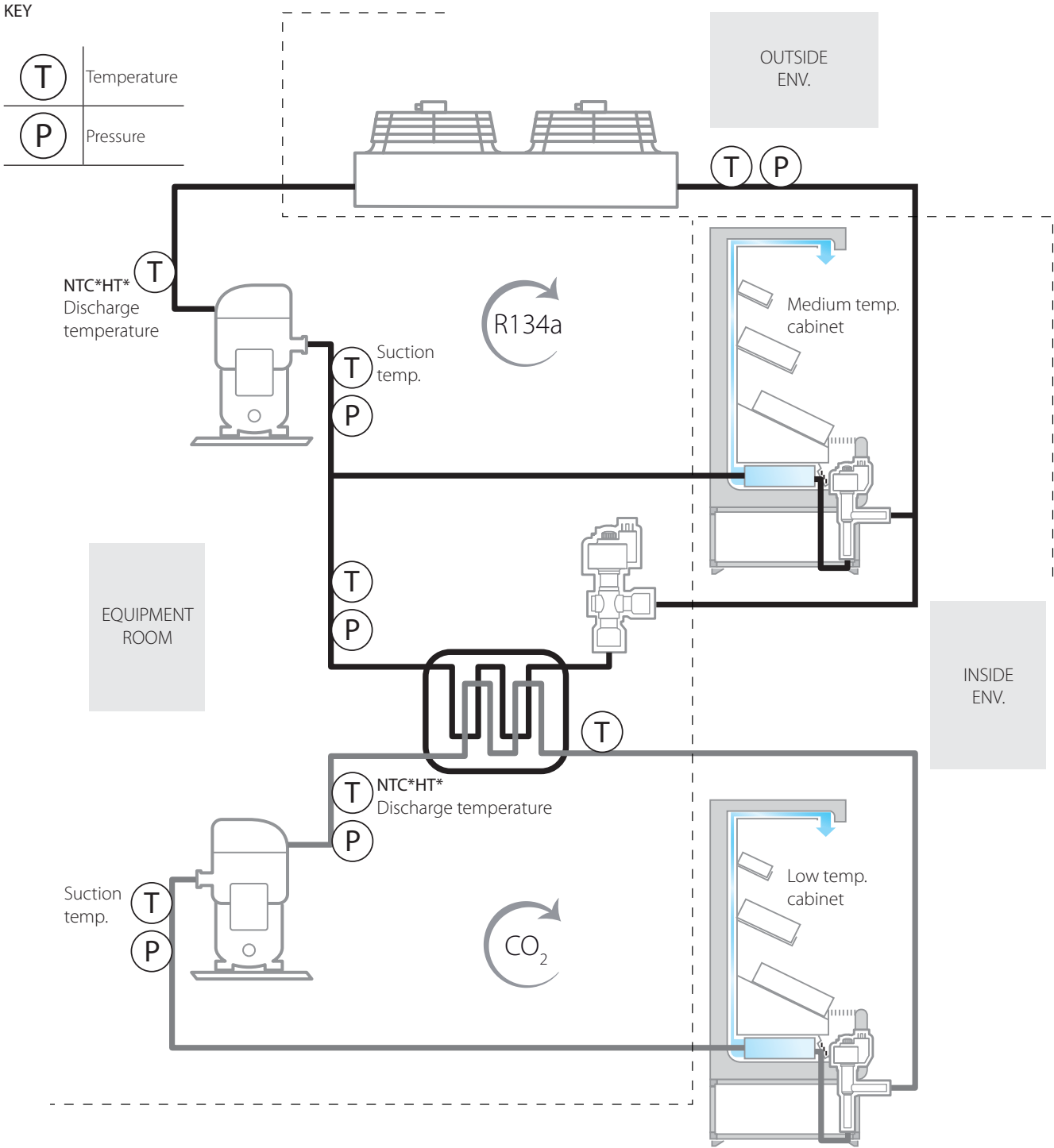

Connection with capillary

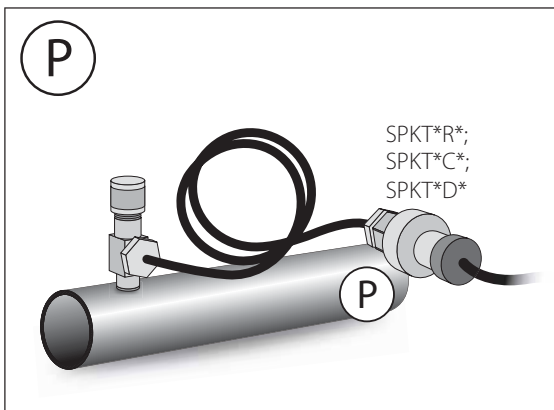

Welded connection

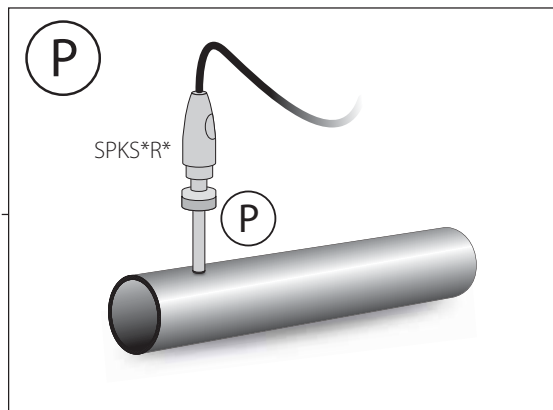

### 13. FURTHER SUGGESTIONS

#### 13.1 Room temperature and humidity sensors

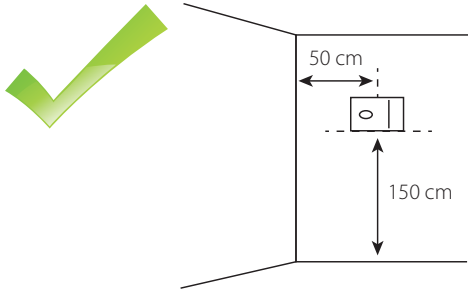

Fig. 13.a

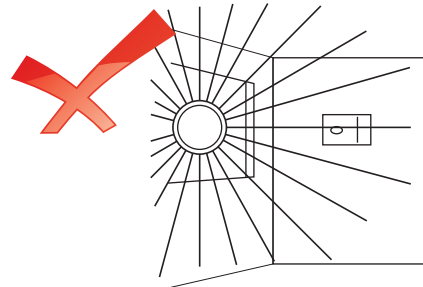

Fig. 13.b

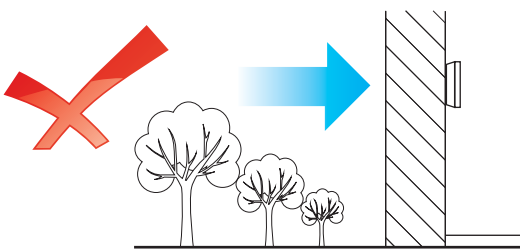

Fig. 13.c

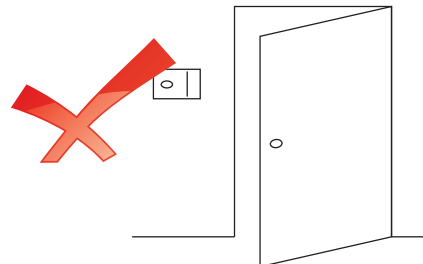

Fig. 13.d

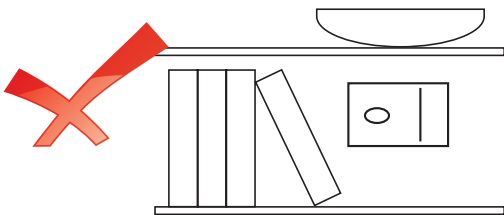

Fig. 13.e

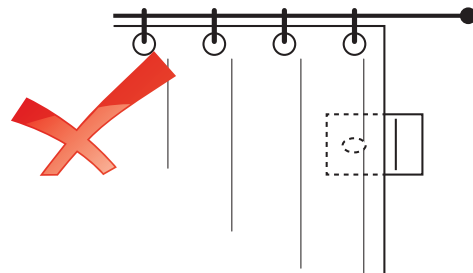

Fig. 13.f

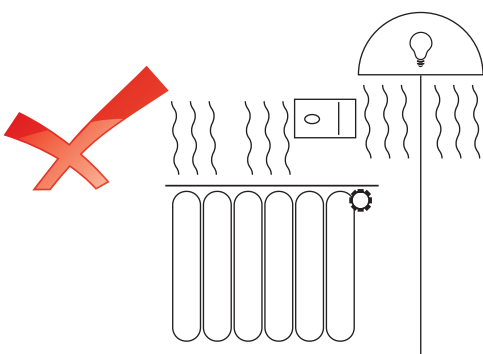

Fig. 13.g

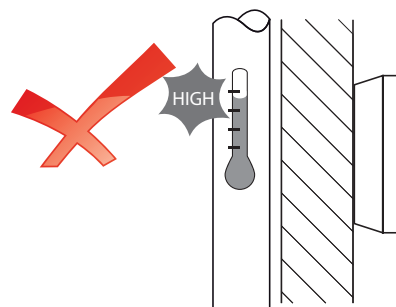

Fig. 13.h

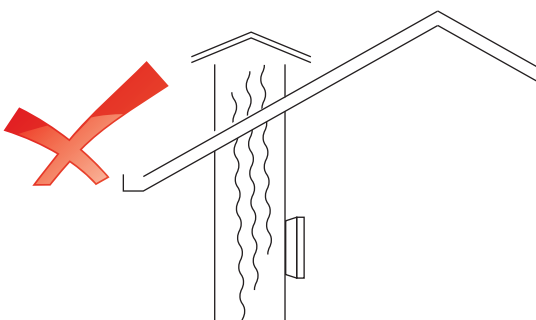

Fig. 13.i

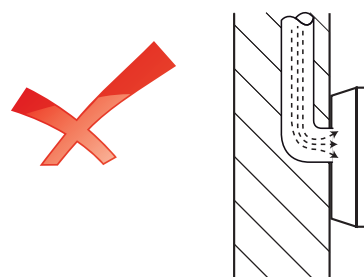

Fig. 13.l

13.2 Duct temperature and humidity sensors

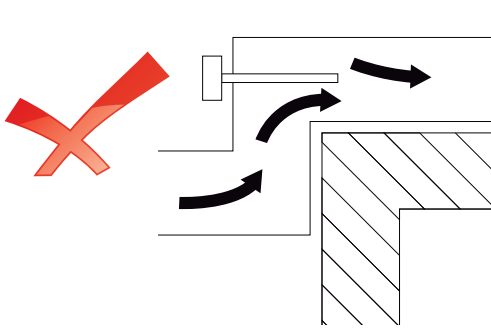

Fig. 13.m

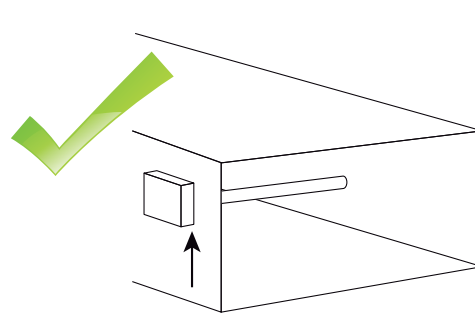

Fig. 13.n

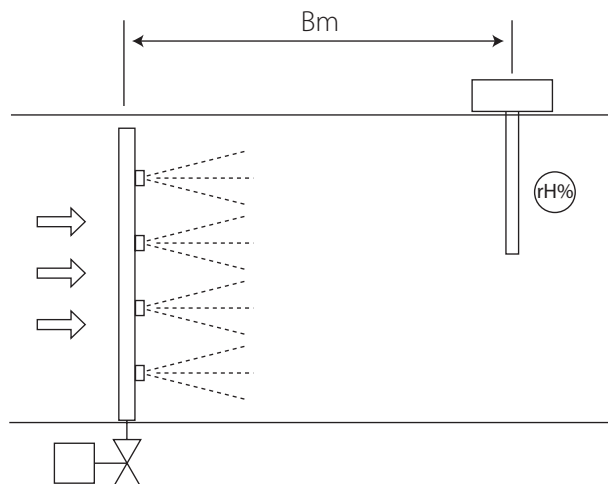
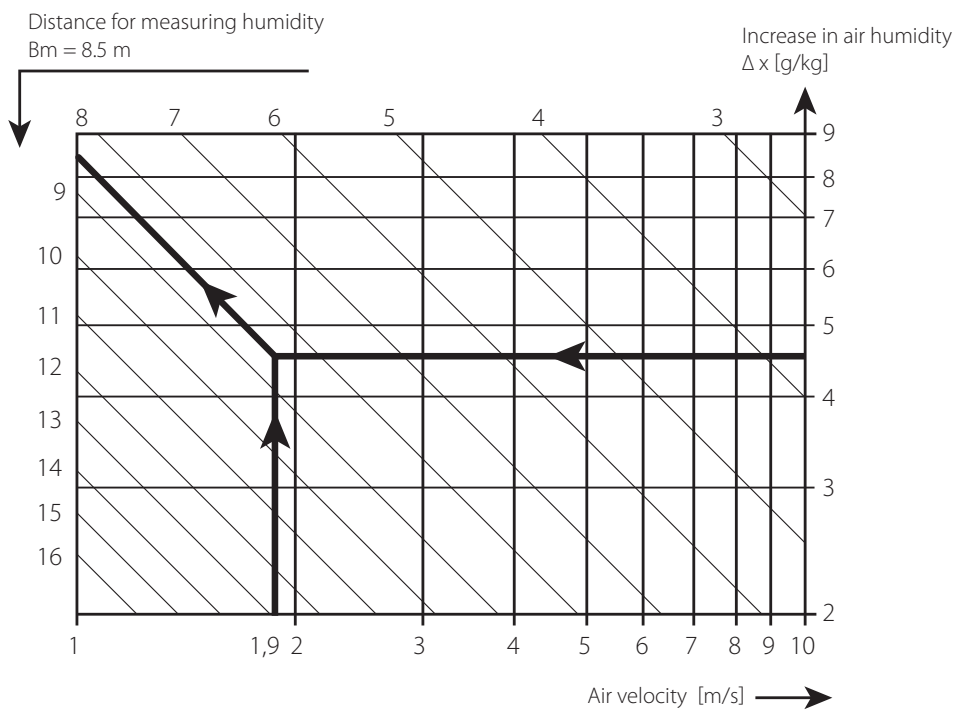

Fig. 13.o

### 13.3 Temperature sensors

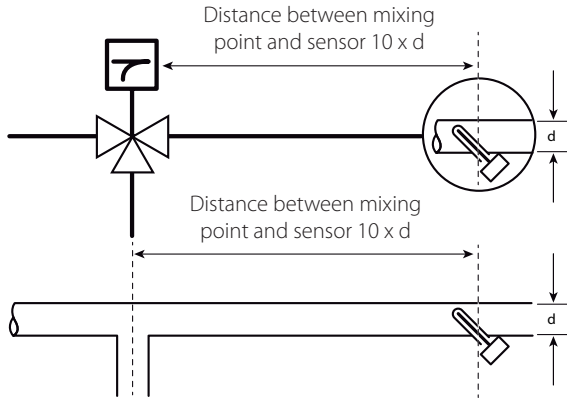

Fig. 13.p

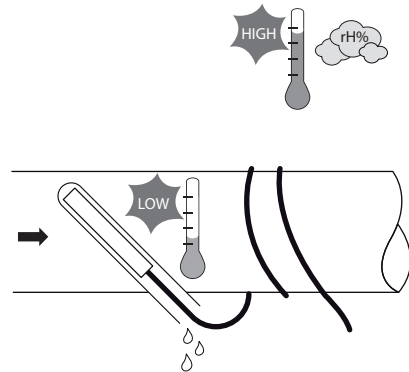

Fig. 13.q

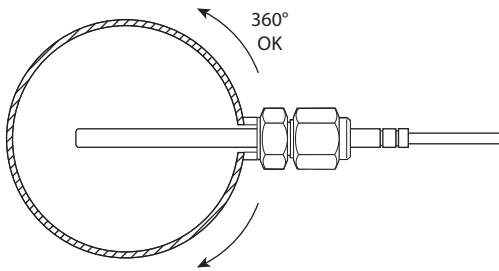

Fig. 13.r

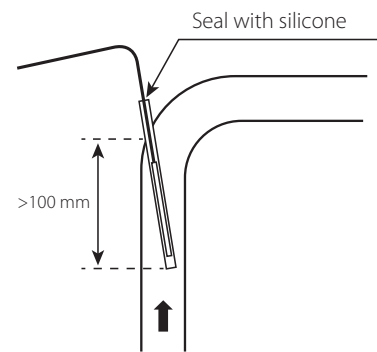

Fig. 13.s

### 13.4 Pressure sensors

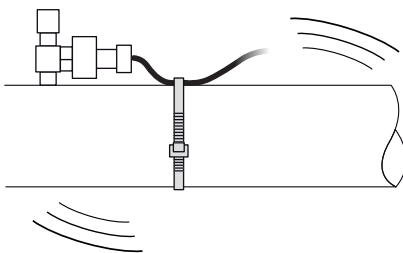

Fig. 13.t

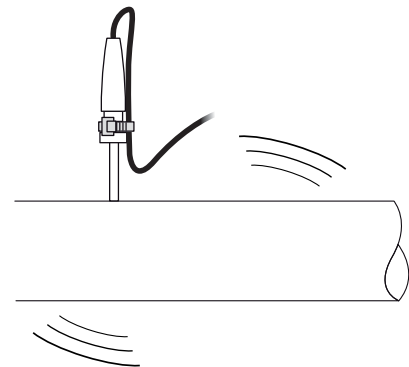

Fig. 13.u

### 13.5 Gas leakage sensors

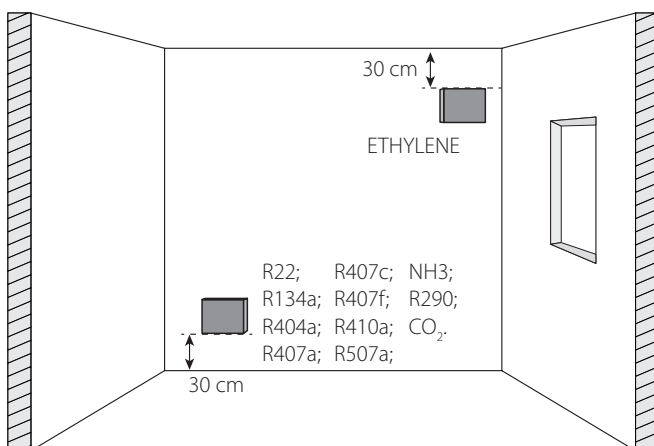

Fig. 13.v



# CAREL

CAREL INDUSTRIES - Headquarters  
Via dell'Industria, 11 - 35020 Brugine - Padova (Italy)  
Tel. (+39) 049.9716611 - Fax (+39) 049.9716600  
e-mail: carel@carel.com - www.carel.com

Agenzia / Agency: